



# EXT Series

## 600lbs Water Proof Electromagnetic Lock

Model EXT275-SL (Monitored Version)



### Description

600lbs Water Proof EM locks were designed as such to be unaffected / resisting the ingress of water under specified condition with its fully sealed electronics incased with stainless steel. Suitable for outdoor application and harsh climate.

### Standard Features



Fail Safe

Life Safety Applications



Zero Residual Magnetism

No Residual



Low Power

Low Energy Consumption



Low Maintenance

Cost Savings

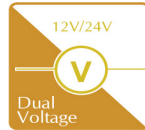

12V/24V Dual Voltage

12/24V Selectable



Waterproof

Fully Sealed Electronics

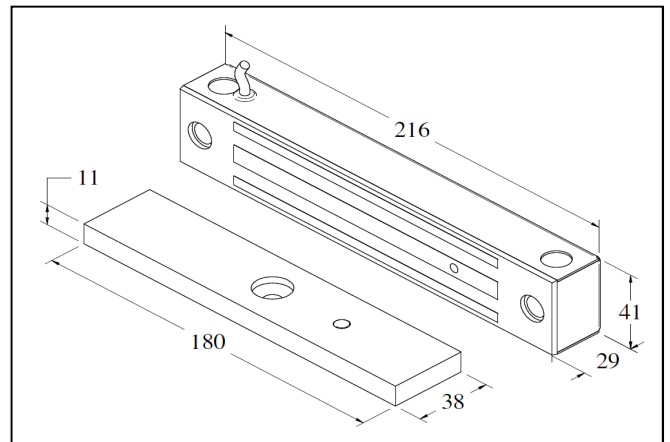

### Features & Technical Specification

Models	EXT275-SL
Features & Spec.	
Lock Status Monitoring	Reed Switch
Holding Force	Up to 600lbs
Magnet Size	216 X 41 x 29 mm
Armature Size	180 X 38 X 11 mm
Current Drain	480mA±10%/12Vdc / 240mA±10%/24Vdc
Temperature	(-10 to 55)°C (14 to 131)°F
Housing	Stainless Steel Housing
Weight	2.31 Kg

### Wiring Diagram

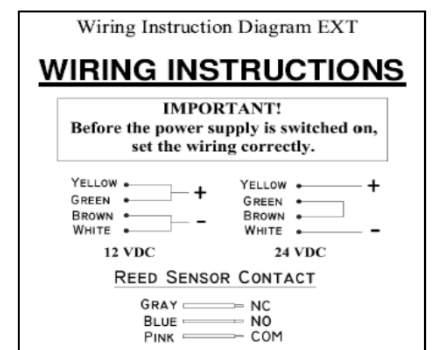

931 ถ.พระราม1 แขวงวังใหม่ เขตปทุมวัน กรุงเทพฯ 10330

โทร. 02-2150105-8, 02-2160318-21, 02-2162901-5, 02-2160309-14

แฟกซ์ : 02-2162907, 02-2162909

Email: info@tanabutr.co.th URL: www.tanabutr.co.th Line ID: @tanabutr

