

## Magnetic Door Lock UL275-SL

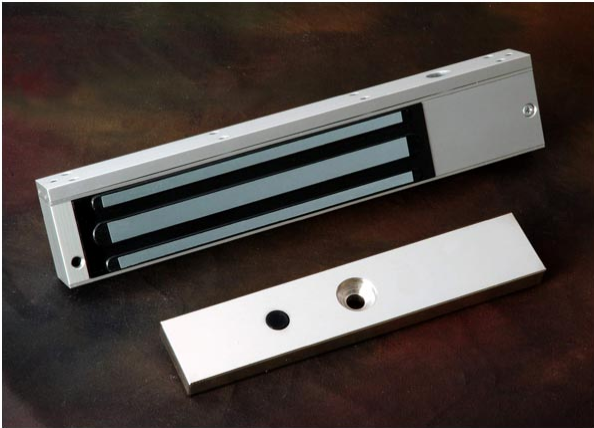

### FEATURES:

1. Holding force : 600lb
2. Anodized aluminum housing
3. Adjustable mounting bracket
4. Voltage : 12 VDC
5. Bond sensor

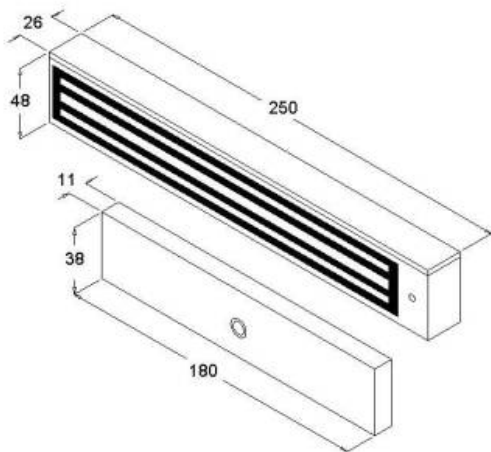

### UL275-SL :

Magnet Size(mm)	250X42X26
Armature	180X38X11
Holding Force	600 lbs
Current Drain	480mA± 240mA±
Temperature	(-10 to 55)C° (14 to 131)F°

### ACCESSORY



**275-GG**

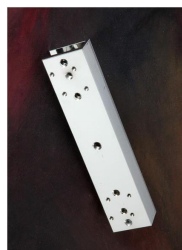

**275-U1**



**275-ZL**