

Star FINGER007/P
iPASS IP-FINGER007
IDTECK FINGER007SR

Fingerprint Identification
Access Control System



Table of Contents

1. Important Safety Instructions	5
2. General.....	6
3. Features	6
4. Specification.....	7
5. Identifying Supplied Parts	9
6. Product Overview.....	9
6.1 FUNCTIONS.....	9
6.2 PRODUCT EXPLANATION	11
6.2.1 PANEL DESCRIPTION	11
6.2.2. COLOR CODED & WIRING TABLE	12
7. Installation Tips & Check Point.....	13
7.1 CHECK POINTS BEFORE INSTALLATION	13
7.1.1 SELECTION OF CABLE	13
7.1.2 RECOMMENDED CABLE TYPE AND PERMISSIBLE LENGTH OF CABLE	13
7.2 CHECK POINT DURING INSTALLATION	14
7.2.1 TERMINATION RESISTOR.....	14
7.2.2 HOW TO CONNECT TERMINATION RESISTORS	15
7.2.3 GROUNDING SYSTEM FOR COMMUNICATION CABLE	15
7.2.4 REVERSE DIODE CONNECTION.....	16
8. Installation of the Product	16
8.1 TEMPLATE.....	16
8.2 BACKUP BATTERY S/W.....	17
8.3 SYSTEM INITIALIZATION (EXTRA READER PORT)	18
8.4 WIRING	18
8.4.1 POWER	18
8.4.2 INPUT CONNECTIONS	19
8.4.3 OUTPUT CONNECTIONS	19
8.4.4 READER CONNECTIONS(EXTRA READER).....	20
9. Communication	20
9.1 RS232 COMMUNICATION PORT CONNECTION	20
9.2 RS-422 COMMUNICATION PORT CONNECTION	20
9.2.1 RS-422 CONNECTION (STAND ALONE).....	20
9.2.2 RS-422 CONNECTION (MULTIPLE FINGER007 CONNECTIONS).....	21
9.3 DIAL UP MODEM	22

9.4 TCP/IP CONVERTER (EXTERNAL VERSION).....	22
10. Operation.....	22
10.1 NORMAL OPERATION.....	22
10.2 DEFAULT SETTING	23
11. Setting Changes.....	24
11.1 SETUP MENU F1	25
11.1.1 READER MODE SETTING	27
11.1.2 TIME SETTING	27
11.1.3 TYPE SELECTION	28
11.1.4 ANTI-PASS-BACK MODE SETTING.....	29
11.1.5 COMMUNICATION ID(ADDRESS) DISPLAY.....	29
11.1.6 SETTING DURESS MODE	30
11.1.7 BAUD RATE SETTING.....	31
11.1.8 EVENT CLEAR.....	31
11.1.9 MASTER ID CHANGE.....	31
11.1.10 SYSTEM INITIALIZE	33
11.1.11 CARD ID CLEAR	33
11.1.12 TIME SCHEDULE CLEAR.....	33
11.1.13 KEYPAD INPUT SETTING	33
11.2 SETUP MENU F2	34
11.2.1 REGISTERING AND CHANGING TIME SCHEDULE	35
11.2.2 REGISTERING AND CHANGING HOLIDAY TIME SCHEDULE	36
11.2.3 DEFINING OUTPUTS IN COMPLIANCE WITH INPUTS	37
11.2.4 HOLIDAY INDEX SETTING.....	38
11.2.5 READER TIME SCHEDULE SETTING	38
11.2.6 LCD DISPLAY FORM SETTING.....	38
11.2.7 OUTPUT TIME UNIT SETTING.....	39
11.3 SETUP MENU F3	39
11.3.1 CARD REGISTRATION.....	40
11.3.2 ID DELETE	42
11.3.3 ID LIST	43
11.3.4 REGISTERED ID COUNT	43
11.3.5 STORED EVENT COUNT	43
11.3.6 STORED FP COUNT	43
11.4 SETUP MENU F4	44
11.4.1 VERSION CHECK.....	44
11.4.2 SRAM TEST	45
11.4.3 OUTPUT TEST.....	45



11.4.4 LCD TEST	46
11.4.5 KEYPAD TEST	46
11.4.6 READER TEST	46
11.4.7 INPUT TEST	46
11.4.8 COMMUNICATION TEST	47
11.4.9 FP VERSION	47
11.4.10 FP MODULE TEST	47
12. APPENDIX	48
13. FCC Registration Information	55
14. Warranty Policy and Limitation of Liability	56
15. Template	57

1. Important Safety Instructions

When using Fingerprint Identification (Proximity / PIN) Time & Attendance Access Controller, basic safety precautions should always be followed to reduce the risk of fire, electrical shock, and injury to persons. In addition, the following safety guides should also be followed:

1. Fully read and understand all instructions and follow them completely.
2. Follow all warnings and instructions marked on the product.
3. Do not use liquid or aerosol cleaners. Use a damp cloth for cleaning. If necessary, use mild soap.
4. Do not use this product near water.
5. Only operate this product using the type of power source indicated. If you are not sure of the type of power supplied to your installation site, consult your dealer or local power company.
6. Never insert objects of any kind into the product or through the cabinet slots as they may touch voltage points and/or short circuit parts possibly resulting in fire or electric shock.
Never spill liquid of any kind on the product.
7. Never disassemble this product by yourself; take the unit to a qualified service center whenever service or repair is required. Opening or removing the covers may expose you to dangerous voltages or other risks. Also, incorrect reassembly can cause electric shock when the unit is subsequently used.
8. Unplug this product from the Direct Current (DC) power source and refer to qualified service personnel under these conditions:
 - a. When the power supply cord or plug is damaged or frayed.
 - b. If liquid has been spilled on the product.
 - c. If the product does not operate normally after following the operating instructions in this manual.

Adjust only those controls that are covered by the operating instructions in this manual. Improper adjustment of other controls that are not covered by this manual may damage the unit and will often require extensive work by a qualified technician to restore normal operation.

- d. If the product exhibits a distinct change in performance.

2. General

The Star FINGER007/P / iPASS IP-FINGER007 / IDTECK FINGER007SR is a highly advanced, intelligent single door controller with a powerful 32bit and dual 8bit microprocessor to meet the market requirement for a robust integrated solution for access control and time & attendance. The unit is designed to be flexible and reliable as well as provide the ultimate in biometric high security at a reasonable cost. This user-friendly device allows you to register up to 1,000 fingerprint IDs (optional 2,000/4,000); add / delete user IDs conveniently; store up to 26,000 transactions in its event buffer; easily report and archive information to Excel or Access databases; and ultimately successfully manage all access control and time & attendance issues. With a built-in 4" RF reader, keypad for Personal Identification Numbers (PIN), and a sophisticated biometric fingerprint analyzer, the Star FINGER007/P / iPASS IP-FINGER007 / IDTECK FINGER007SR offers up to three levels of ID verification. Any combination of proximity, PIN, and biometric may be used and different verification levels can be custom programmed for each user or user group. Four independent input ports can be utilized for a wide variety of controls including exit buttons, door contacts, PIR sensors and fire detection equipment. Actions to be taken and time settings can be programmed with the front keypad or via the intuitive Windows based software program. The Star FINGER007/P / iPASS IP-FINGER007 / IDTECK FINGER007SR can be used both as a stand-alone system and also be networked. All control setting values such as ID numbers, inputs/outputs, real-time clock, time schedules, and event transaction reports can be uploaded and/or downloaded to and from the host computer. The compact and contemporary unit is easily installed and programming requires no significant knowledge of access control or time & attendance. The Three-LED indicator lights inform you of the systems operating status at real time and the digital display acts as a programming aid as well as a regulation time clock. By bundling the ultimate in high security access control and comprehensive employee management tools into a compact user friendly unit, the field proven Star FINGER007/P / iPASS IP-FINGER007 / IDTECK FINGER007SR has made real what until recently was thought only to be possible in science fiction.

3. Features

- 125KHz Proximity / PIN and Fingerprint Recognition
- Dual Function for Access Control and Time & Attendance
- 1,000 / 2,000 / 4,000 Fingerprint Users / 26,000 Event Buffers
- 1:1 Verification and 1: N Identification Storable 2 Fingerprint Templates
- Identification Method by PIN Key (Default)
 by Auto Touch Sensor (Optional) : FINGER007A, FINGER007PA

- ID Only Function for Fingerprint Unregisterable Person
- Standalone / Network Communication via RS232 / RS422 / RS485 (Max.32ch),
 TCP/IP (External LAN Converter Required)
- 1 ea of External Reader Port for Anti-Pass-Back Function: 26bit Wiegand, 4 / 8bit Burst for PIN
- Independent 4 Inputs and 4 Outputs Including 2 Form-C Relay Outputs
- High Protection from Scratch and ESD (Electro Static Discharge)
- High Quality Optical Sensor
- Dual Tamper Switches

- Alarm Event Monitoring using Tamper Switch (by Application Software)
- Options:
 - 1,000 / 2,000 / 4,000 Fingerprint Users
 - Auto Touch Sensor for Identification (FINGER007A, FINGER007PA)
- Compatible Software: STARWATCH DUAL PRO I / II

* Comparison Table

FINGER007	Built in 125KHz (4") Proximity Reader
	RF(PIN) Only / Fingerprint Only / RF(PIN)+Fingerprint RF(PIN)+P/W(4digit) / RF+P/W+Fingerprint
IP-FINGER007	ASK[EM] Format, Built in 125KHz (4") Proximity Reader
	RF(PIN) Only / Fingerprint Only / RF(PIN)+Fingerprint RF(PIN)+P/W(4digit) / RF+P/W+Fingerprint
FINGER007SR	Built in 13.56MHz (4") Contactless Smart Card Reader
	Smart Only / Fingerprint Only / Smart+Fingerprint Smart+P/W(4digit) / Smart+P/W+Fingerprint
FINGER007P	PIN(4~8digit) Only / Fingerprint Only / PIN+Fingerprint PIN+P/W(4digit) / PIN+P/W+Fingerprint
FINGER007A	FINGER007 including Auto Touch Sensor for Identification
IP-FINGER007A	IP-FINGER007 including Auto Touch Sensor for Identification
FINGER007SRA	FINGER007SR including Auto Touch Sensor for Identification
FINGER007PA	FINGER007P including Auto Touch Sensor for Identification

4. Specification

Model			FINGER007	FINGER007P
CPU			32bit ARM9 and Dual 8bit Microprocessor	
Memory	Fingerprint Module	Program Memory	Program Flash:1Mbytes	
		Data Memory	DB Flash Memory: 1/2/4 Mbytes	
	Controller	Program Memory	64KByte Flash Memory	
		Data Memory	512KByte SRAM (Battery back up)	
Fingerprint User			1,000 / 2,000 / 4,000 Fingerprint Users	
Fingerprint Templates Size			800 Bytes for 2 Fingerprint Templates	
Event Buffer			26,000 Event Buffers	
Read Range	Passive Type	FINGER007	IDK50 / IMC125 : Up to 2 inch (5cm) IDC80 / IDC170: Up to 4 inch (10cm)	PIN Only
		IP-FINGER007	IPK50: Up to 2 inch (5cm) IPC80 / IPC170: Up to 4 inch (10cm)	
		FINGER007SR	ISK50 / IHC80 / IMC135: Up to 2 inch (5cm)	

		ISC80:Up to 4 inch (10cm)
	Active Type	IDA150 / IDA200 Compatible
Reading Time (Card)		30ms
Verification / Identification Time		Less than 1sec. / Less than 2sec.
Power / Current		DC 12V / Max.300mA
External Reader Port	FINGER007 / IP-FINGER007	1ea (26bitWiegand, 4 / 8bit Burst for PIN) for Anti-Pass-Back
	FINGER007SR	1ea (34bitWiegand, 4 / 8bit Burst for PIN) for Anti-Pass-Back
Communication		RS232 / RS422 / RS485 (Max.32ch)
		TCP/IP (External LAN Converter Required)
Baud Rate		9,600bps (Default) / 4,800bps, 19,200bps and 38,400bps (Selectable)
Input Port		4ea (Exit Button, Door Sensor, Aux# 1, Aux#2)
Output Port		2ea (FORM-C Relay Output (COM, NO, NC) / DC12V~18V, Rating Max.2A)
		2ea (TTL Output / DC5V, Rating Max.20mA)
LCD		Character LCD (2 Lines x 16 Char) / 65.6mm x 13.8mm (2.62" x 0.55") Screen
Keypad		16 Key Numeric Keypad with Back Lighting
LED Indicator		3 Array LED Indicators (Red, Green and Yellow)
Beeper		Piezo Buzzer
Operating Temperature	Fingerprint Module	-15° to +40°C (+5° to +104°F)
	LCD	0° to +50°C (+32° to +122°F)
	Controller	-15° to +70°C (+5° to +158°F)
	RF Reader	-35° to + 65°C (-31° to +149°F)
Operating Humidity		10% to 90% relative humidity non-condensing
Color / Material		Dark Pearl Gray / Polycarbonate
Dimension (W x H x T)		6.36" x 5.28" x 1.9" (161.5mm x 134mm x 48.5mm)
Weight		547g (1.21lbs)
Certification		UL, FCC, CE, MIC

* Fingerprint Module Specification

Resolution	500Dpi
Capture Image Size	412 X 302 pixels
Extraction Image Size	260 X 300 pixels
Sensing Area	13mm X 15.2mm
Scanner	High Quality Optical Sensor
FAR(False Acceptance Ratio)	0.001%
FRR(False Reject Ratio)	0.1%
ESD(Electro Static Discharge)	15KV
Verification Time	Less than 1sec.
Identification Time	Less than 2 sec.

5. Identifying Supplied Parts

Unpack and check the contents. If any of these parts are missing, contact a distributor nearby.



Main Unit
(1 ea)



Wall Mount
(1 ea)



O-ring
(5 ea)



User's Manual
(1 ea)



Diode
(2ea)

6. Product Overview

6.1. Functions

Stand-Alone Operation

The Star FINGER007/P / iPASS IP-FINGER007 / IDTECK FINGER007SR is capable of having two readers(entry and exit). The unit receives card data signals from the RF readers and determines whether or not to unlock the door. When an input signal is sent, for example from an activated sensor or if the exit button is pressed, the controller generates and logs an appropriate response. All events are kept in its memory and sent to the host computer. The access controller is a true standalone device that in the event of a malfunction, will not affect other units, even if used in conjunction with one another.

Operation with Host Computer

All event transactions can be managed via the host computer. The data transmitted from the controller can be displayed and stored on the host PC.

Data Backup

All user information and event data are retained for 30 days, even in power failure.

CAUTION: Battery Switch needs turning on before 1st run.

(See the INSTALLATION section)

Keypad

The built-in keypad and LCD let you perform manual programming w/o PC connected.

Dual Finger Mode

Dual Finger Mode is a function that lets a user register two fingers for one ID so that the user can receive authentication with either of the two registered fingers. This is useful when a user's finger is injured.

Anti-Pass-Back

An additional exit proximity reader is required to use this function. Anti-Pass-Back mode prevents any entry or exit when a registered user has violated the one-entry-one-exit rule. That is, a user who didn't enter with a proper authentication process won't be allowed to exit by the exit reader and vice versa. You can't enter or exit twice in a row.

This function effectively helps get rid of the buddy-punching problem.

Input/Output

The STAR FINGER007 has built-in 4 inputs and 4 outputs (2 relay outputs and 2 TTL outputs) which can be used to manipulate a wide variety of controls.

Time Schedule Setup

You can program 10 time schedules and apply one time schedule to each user. Each time schedule has 8 different time zones from Monday to Sunday(7 time zones) and one holiday. Each time zone has 5 different time codes so you can program 5 different time codes to each day. Also you can program time schedule for individual inputs and outputs. Note that the time schedule for input is activated time code for input device so that the input is activated during the time code on this time schedule. Each time schedule is linked to one of holiday schedule and this linked holiday only validates to holiday time code of the time schedule.

Holiday Schedule Setup

Excepting Sunday, you can program 32 holidays to one holiday schedule. Each holiday schedule is linked to one time schedule which has time code for holidays. So you can program all holidays to holiday schedule and the time code for holidays is programmed to holiday time zone of time schedule.

Example : A : Holiday schedule 01 linked to time schedule 01,
 Holiday schedule 02 linked to time schedule 02.
 B : Holiday schedule 02 linked to time schedule 01,
 Holiday schedule 01 linked to time schedule 02.

Forced Door Open and Door Open Alarm

When door is opened by force, Door Contact Output is generated. And, when the door is being opened by normal operation, after 20 sec. door-open alarm(blink buzzer) will be generated until the door is closed.

Duress Alarm

You can select Duress Mode enable or disable. If you select Duress Mode enable, in case of Duress, enter the 2 digit Duress Password and press <ENT> and open the door using general process. If you registered ID, then Duress Output will be generated, and alarm event will be sent to the host PC.

1:N Certification (IDENTIFICATION)

You can certify using the fingerprint alone without RF card or PIN. You can set this function through the <TYPE SELECTION> in SETUP MENU F1.

In the IDENTIFICATION MODE, the security level gets higher automatically, FRR(False Rejection Ratio) as well, but FAR(False Accept Ratio) gets lower, which may result in a lower recognition ratio. When using this mode, you have to press the <ENT> key first, then the fingerprint scanner waits for a fingerprint to be scanned. When a fingerprint-

scanning is completed, FINGER007 compares the data and makes corresponding outputs.

- FINGER007(of V4.75 or higher) has a sensor(finger detect).So in identification mode, you need not enter <ENT> key. If you touch at finger sensor, Finger007 detects your finger and scanning automatically.

CAUTION : The number of registrants must be 50 or less.

Adaptive Mode

When fingerprint sensor gets fingerprint image, "Adaptive Mode" improves a dry or wet fingerprint. You can set this function through the <TYPE SELECTION> in SETUP MENU F1. When you select "Adaptive Mode in USE", fingerprint image is improved even dry or wet finger during registration or identification. Thus this mode has higher identification rate but it takes longer identification time due to the processing time of the fingerprint image.

6.2 PRODUCT EXPLANATION

6.2.1 PANEL DESCRIPTION

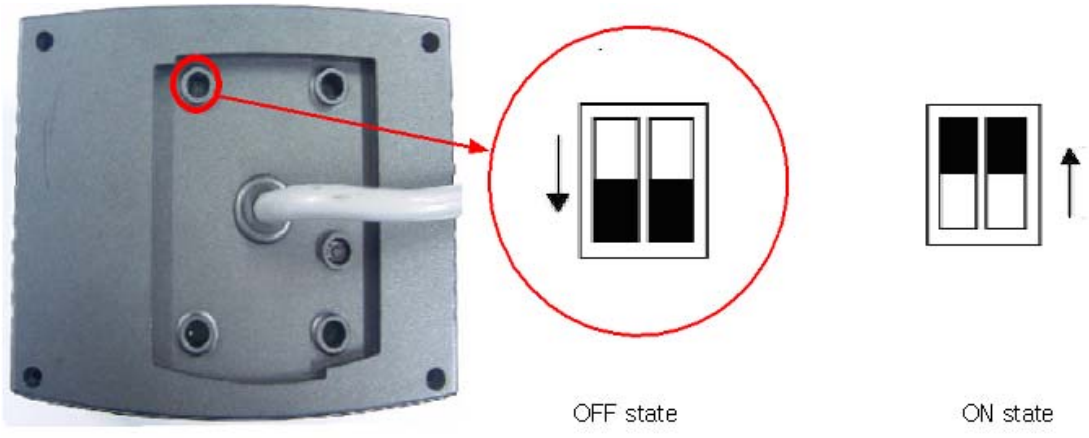
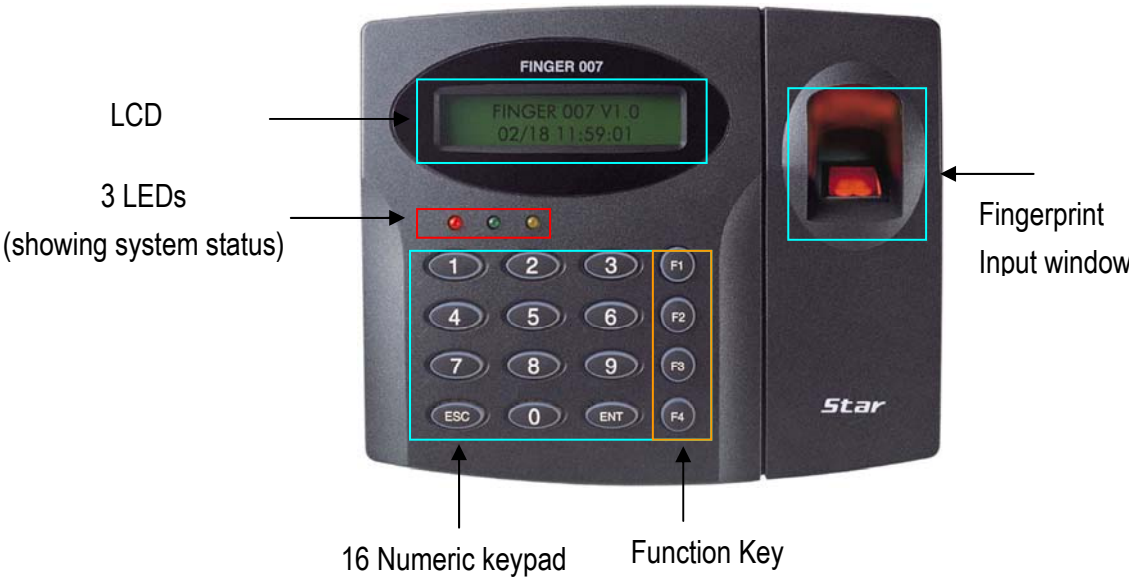

BAT connection S/W

- FINGER007(of V4.70 or higher) has a S/W(reverse side – Template hole) for the backup battery connection. Before the FINGER007 installation, it needs to be connected before H/W initialize so that backup battery can retain the memory during power failure.

6.2.2. Color Coded & Wiring Table

SIGNAL	COLOR
Main Power (+12V)	Red
Power Ground (GND)	Black
Door Relay Out (COM)	Gray with Red stripe
Door Relay Out (NC)	Blue with White stripe
Door Relay Out (NO)	White with Red stripe
Alarm Relay Out (COM)	White
Alarm Relay Out (NC)	Purple with White stripe
Alarm Relay Out (NO)	Purple
TTL Out 1	Orange with White stripe
TTL Out 2	Brown with White stripe
Exit Button In	Orange
Door Contact In	Yellow with Red stripe
Aux In 1	Green
Aux In 2	Green with White stripe
Wiegand Data 0 In	Pink
Wiegand Data 1 In	Cyan
RS232 (TX)	Black with White stripe
RS232 (RX)	Red with White stripe
RS422 (TX+)	Gray
RS422 (TX-)	Yellow
RS422 (RX+)	Brown
RS422 (RX-)	Blue
* Please cut out tail connector before installation.	

7. Installation Tips & Check Point

Installing the Star FINGER007/P / iPASS IP-FINGER007 / IDTECK FINGER007SR is an easy task. It can be installed with common hand tools and readily available communications wires. This section provides information about wiring, wire runs and other information to make the installation quick and easy.

7.1 CHECK POINTS BEFORE INSTALLATION

7.1.1 SELECTION OF CABLE

System installation cabling will be configured as follow.

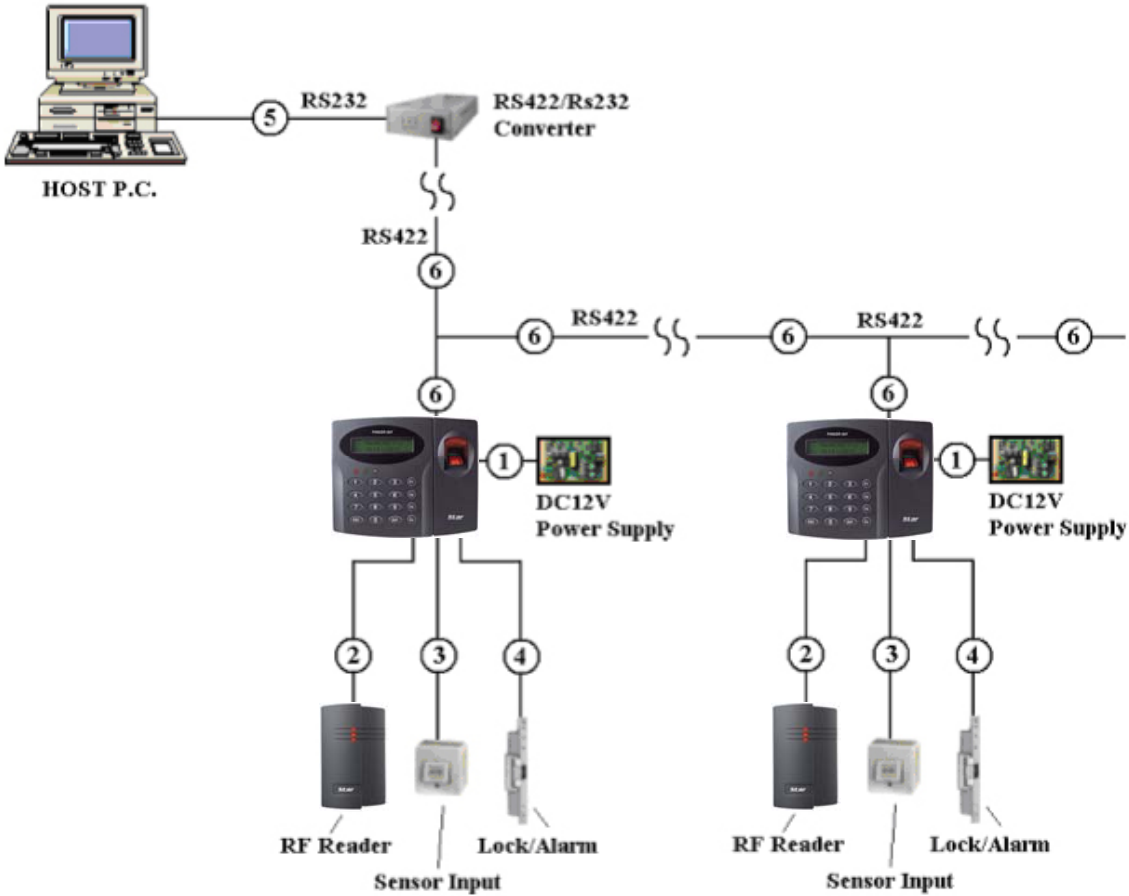

Figure: System Installation Layout

7.1.2 RECOMMENDED CABLE TYPE AND PERMISSIBLE LENGTH OF CABLE

Reference	Description	Cable Specification	Maximum Distance
①	Finger007 Power (DC12V) DC Power -> Finger007	Belden #9409, 18 AWG 2 conductor, unshielded	30m

②*	Reader (Power and Data) Extra Reader -> Finger007	Belden #9512, 22 AWG 4 conductor, shielded	150m
		Belden #9514, 22 AWG 8 conductor, shielded	
③	Door Contact Exit Button Sensor Input Input -> Finger007	Belden #9512, 22 AWG 4 conductor, shielded	300m
		Belden #9514, 22 AWG 8 conductor, shielded	
④	Door Lock, Alarm Device Lock (Alarm) -> Finger007	Belden #9409, 18AWG 2 conductor, unshielded	300m
⑤	RS232 Cable Converter -> Host P.C.	Belden #9829, 24 AWG 2-twisted pair, shielded	15m
⑥	RS485 Cable Finger007 -> Finger007 Finger007 -> Converter	Belden #9829, 24 AWG 2-twisted pair, shielded	1,200m
	RS422 Cable Finger007 -> Finger007 Finger007 -> Converter	Belden #9830, 24 AWG 3-twisted pair, shielded	

*: Need thicker wire if you connect the reader with high current consumption.

7.2 CHECK POINT DURING INSTALLATION

7.2.1 TERMINATION RESISTOR

Termination resistors are used to match impedance of the network to the impedance of the transmission line being used. When impedance is mismatched, the transmitted signal is not completely absorbed by the receiver and a portion of signal is reflected back into the transmission line.

The decision whether or not to use termination resistors should be based on the cable length and data rate used by the communication system.

For example, if you use 9,600 baud rate and 1,200m length of cable, the propagation velocity of cable is 0.66 x speed of light (This value is specified by the cable manufacturer), if we assume the reflections will damp out in three round trip up and down the cable length, the transmitted signal will stabilize 18.6us after the leading edge of a bit. Since the data bit is captured in the middle of the bit which is approximately 52us after the leading edge of a bit. The reflection stabilizing time 18.6us is much before the center of the bit therefore the termination resistors are not required.

However, if you install the cable to maximum length, the impedance of cable and network is mismatched and the transmitted signal is overlapped by the reflected signal. In this case, it is recommended to add termination resistors to the end of the receiver

lines. A 120Ω resistor can be used for termination resistor in parallel between the receiver lines “A” and “B” for 2 wires RS485 system or “RX+” and “RX-” for 4 wires RS422 system. A termination resistor of less than 90Ω should not be used and no more than 2 terminations should be used in one networking system.

7.2.2 HOW TO CONNECT TERMINATION RESISTORS

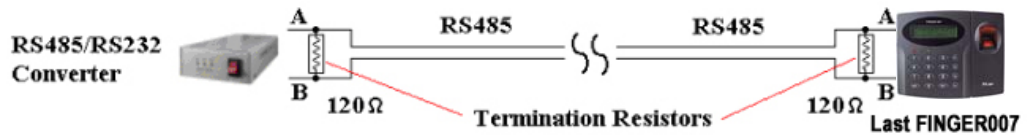

Figure: Termination resistors for 2 wire RS485 communication system

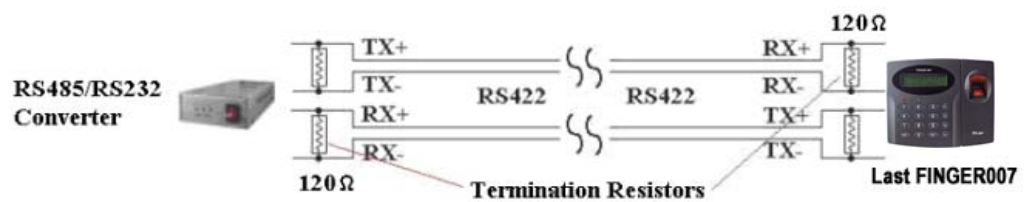

Figure: Termination resistors for 4 wire RS422 communication system

7.2.3 GROUNDING SYSTEM FOR COMMUNICATION CABLE

We recommend to using proper grounding system on the communication cable. The best method for grounding system is to put the shield wire of the communication cable to the 1st class earth grounding; however it is not so easy to bring the earth ground to the communication cable and also the installation cost is raised.

There will be three grounding point where you can find during installation;

- 1) Earth Ground
- 2) Chassis Ground
- 3) Power Ground

The most important point for grounding system is not to connect both ends of shield wires to the grounding system; in this case there will be a current flow through the shield wire when the voltage level of both ends of shield wire is not equal and this current flow will create noise and interfere to communications.

For the good grounding, we recommend to connecting ONLY one end of shield wire of communication cable to grounding system; If you find earth ground nearby, then connect one end of shield wire to earth ground; If you do not have earth ground nearby, then find chassis ground and connect one end of shield wire to chassis ground; If you do not find both earth ground and chassis ground, then connect one end of shield wire to power ground. (GND of FINGER007)

Note that if the chassis ground is not properly connected to the earth and floated from the ground level, then grounding to the chassis ground will give the worst

communication; in this case we recommend to using power ground instead of chassis ground.

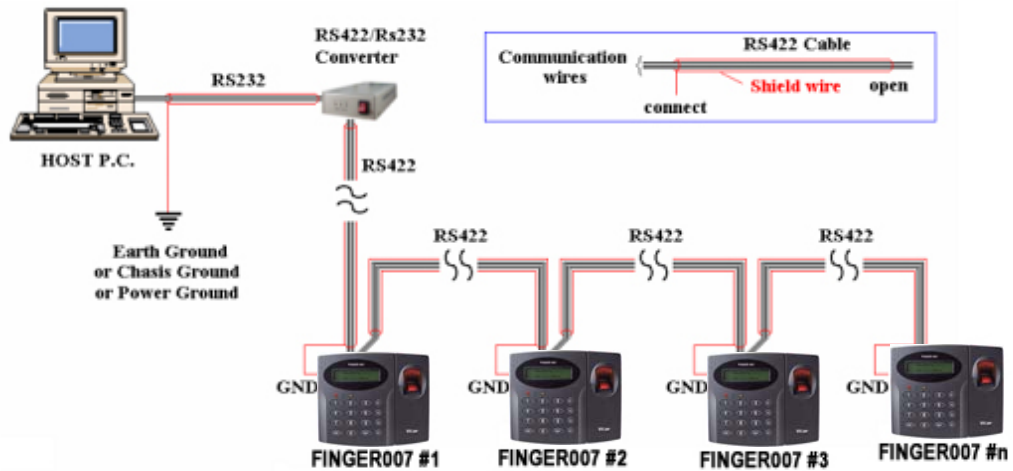

Figure : Grounding system

7.2.4 REVERSE DIODE CONNECTION

If you connect an inductor (Door Locks or Alarm device) to the output relays, there will be a high surge voltage created while the inductor is turning on and off. If you do not connect reverse diode, the surge voltage will transfer and damage to the electronic circuit of the controller. It is strongly recommended to add a reverse diode between the inductor coils to absorb this surge voltage.

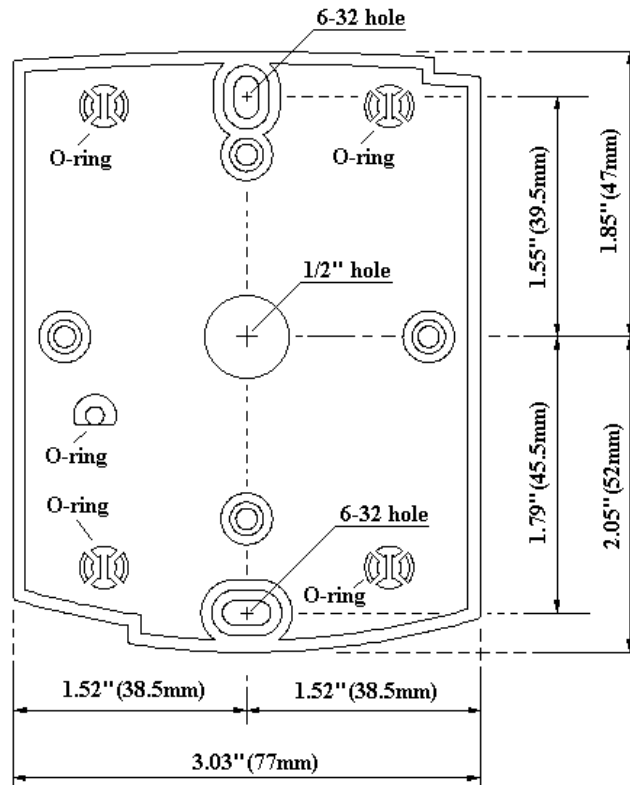

Figure : Reverse Diode connection

8. Installation of the Product

8.1 TEMPLATE

- Tear off last page and use provided template to drill two 6-32 holes and one 1/2" hole on the proper location of the wall to mount the Wall Mount bracket as shown below.
 (If the gang box is already installed on the wall then skip this step.)



- Using 2 screws, install wall mount to the wall.

※ **Caution:** Before mounting the Star FINGER007/P / iPASS IP-FINGER007 / IDTECK FINGER007SR unit to the Wall Mount bracket, an operational test of the unit should be completed, because the locking pins will lock the unit to the Wall Mount. Removing the unit from the Wall Mount bracket after it has been snapped in place may cause damage to the bracket and prevent reattachment.

- Insert 5 O-Rings to the Wall Mount as indicated, then run the cable from the main unit through the center hole and snap in place the main unit to Wall Mount. Make sure that the main unit is securely locked in place with Wall Mount.

8.2 BACKUP BATTERY S/W

FINGER007(of V4.70 or higher) has a S/W(reverse side – Template hole) for the backup battery connection, which is left open circuit to prevent any current consumption of backup battery (Figure : S/W setting).

Before the FINGER007 installation, it needs to be connected so that backup battery can retain the memory during power failure.

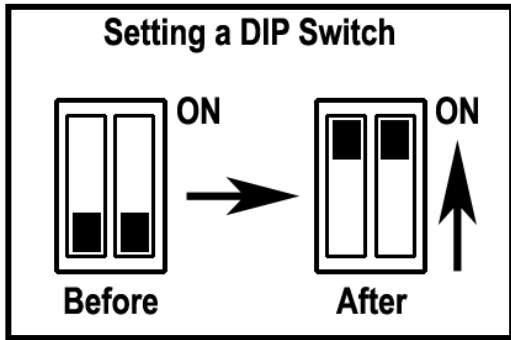

Figure : DIP Switch Setting

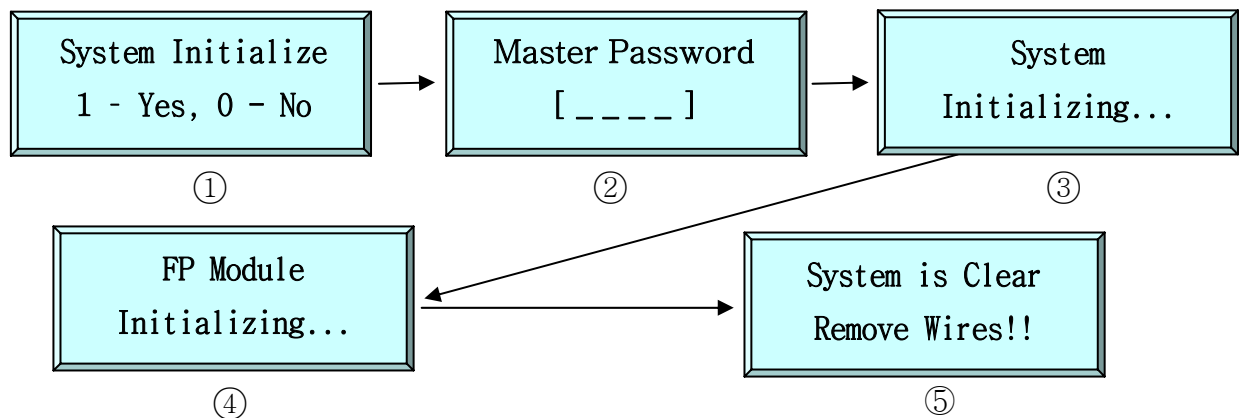

Figure : DIP Switch location

8.3 SYSTEM INITIALIZATION (Extra Reader Port)

You must operate H/W initialization, before the FINGER007 installation.
Of V4.70 or higher, you must connect battery backup S/W in reverse side before H/W initialization.

You can H/W initialize using extra reader port. First, turn off the system power and connect 3 wires (pink, cyan and black(GND)), and turn on the system power. Then you can hear "Initialize beep" and display ① picture.



1. ① : If you want H/W initializing, enter key <1>.
2. ② : Enter initial master password(<3141>).
3. ③, ④ : Showing initializing.
4. ⑤ : After initializing – Main power OFF and separate 3 wire and main power ON again.

8.4 WIRING

8.4.1 POWER

- Connect (+) wire of DC 12V power to +12V(Red wire) terminal.
- Connect GND(-) wire of DC 12V power to GND(Black wire) terminal.

8.4.2 INPUT CONNECTIONS

Exit Button Connection (EXIT)

- Connect one wire from an Exit Button to EXIT(Orange wire).
- Connect the other wire from the Exit Button to the GND(Black wire).

Door Contact Sensor Connection (CONTACT)

- Connect one wire from a Door Contact Sensor to CONTACT(Yellow with Red stripe).
- Connect the other wire(NC) from the Door Contact Sensor to GND(Black wire).

Auxiliary Input Connection (Applied IN1, IN2)

- Connect one wire from an Auxiliary Input Device to one of the IN1(Green wire), IN2(Green with White stripe).
- Connect the other wire from the Auxiliary Input Device to GND(Black wire).

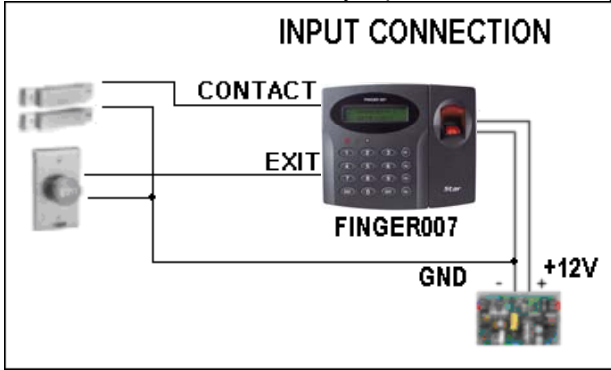

Figure: INPUT DEVICES CONNECTION

8.4.3 OUTPUT CONNECTIONS

Door Lock (Power Fail Safe) Connection (Relay 1)

- Connect COM port of Relay 1 to + 12V.
- Connect NC port of Relay 1 to (+) wire of door lock device.
- Connect GND port to (-) wire of door lock devices.

Door Lock (Power Fail Secure) Connection (Relay 1)

- Connect COM port of Relay 1 to + 12V.
- Connect NO port of Relay 1 to (+) wire of door lock device
- Connect GND port to (-) wire of door lock devices

Alarm Device Connection (Relay 2)

- Connect COM port of Relay 2 to + 12V.
- Connect NO port of Relay 2 to (+) wire of Alarm devices.
- Connect GND port to (-) wire of Alarm devices

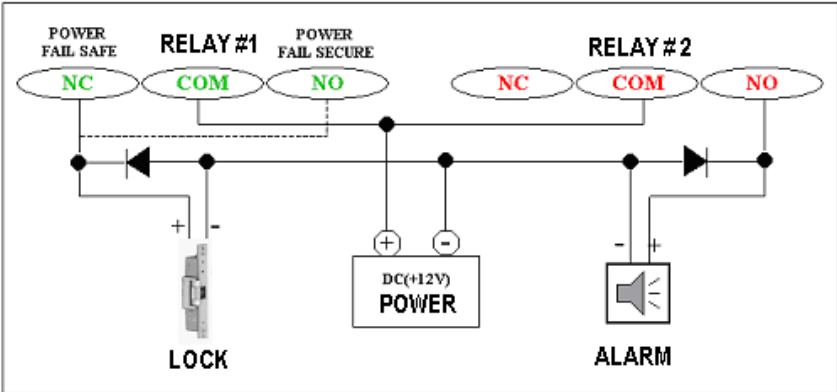

Figure : DOOR LOCK, ALARM DEVICE CONNECTION

CAUTION : Please add one DIODE as shown above.

DIODE : Fast recovery DIODE(current : Min. 1A), 1N4001 ~ 1N4007 or similar

8.4.4 READER CONNECTIONS(Extra Reader)

- Proximity Reader Connection
 - Connect (+)wire of the Proximity Reader to +12V(Red wire)
 - Connect (-)wire of the Proximity Reader to GND(Black wire)
 - Connect DATA0 wire of the Proximity Reader to DATA0 (Pink wire)
 - Connect DATA1 wire of the Proximity Reader to DATA1 (Cyan wire)
- Compatible Readers(Extra Reader)
 - FINGER007/IP-FINGER007:
 - Standard 26bit Wiegand Format Proximity Readers
 - Standard 26bit Wiegand + 8bit Burst Format Proximity and keypad Reader
 - FINGER007SR:
 - Standard 34bit Wiegand Format Proximity Reader
 - Standard 34bit Wiegand + 8bit Burst Format Proximity and keypad Reader
- Recommended Readers
 - FINGER007: RF-TINY, RF10/20/30/70/500, RFK101, FGR006, FGR006EX
 - IP-FINGER007: IP10/20/30, IPK101
 - FINGER007SR: SR10/20/30, SRK101, FGR006SRB

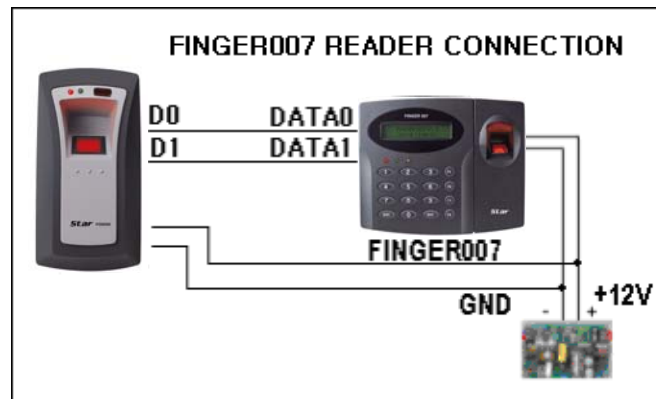

Figure : READER CONNECTION

9. Communication

9.1 RS232 COMMUNICATION PORT CONNECTION

A 9-pin connector (Serial communication connector, female) is required to connect the FINGER007 to a host computer via RS232 communication. Please follow the instructions.

- Connect RS232-TX port of FINGER007 to the pin 2 of the 9-pin connector.
- Connect RS232-RX port of FINGER007 to the pin 3 of the 9-pin connector.
- Connect RS232-GND of FINGER007 to the pin 5 of the 9-pin connector.

Plug in the 9-pin connector to COM1 or COM2 Port of the host PC.

Install and run FINGER007 Application Software.

9.2 RS-422 COMMUNICATION PORT CONNECTION

9.2.1 RS-422 CONNECTION (STAND ALONE)

RS422/RS232 converter(CNP200) is required to use RS422 communication between the FINGER007 and a host computer. Please follow the instructions.

- Connect RS422-TX(+) of the FINGER007 to RS422-RX(+) port of the converter.
- Connect RS422-TX(-) of the FINGER007 to RS422-RX(-) port of the converter.
- Connect RS422-RX(+) of the FINGER007 to RS422-TX(+) port of the converter.
- Connect RS422-RX(-) of the FINGER007 to RS422-TX(-) port of the converter.
- Plug in the RS232 9pin connector of the converter to the COM1 or COM2 Port of the PC.
- Install and run FINGER007 Application Software.

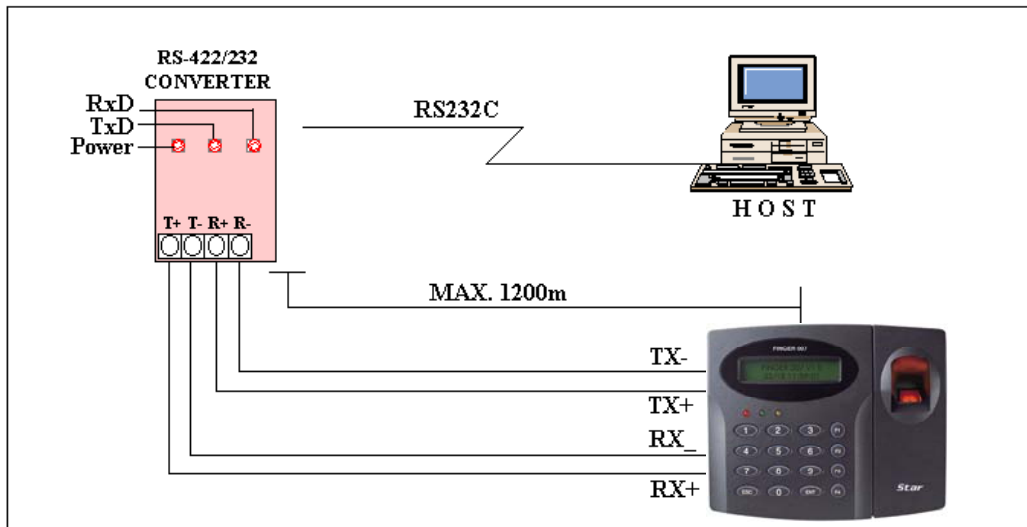

Figure : RS422 Communication between FINGER007 and Host PC

9.2.2 RS-422 CONNECTION (MULTIPLE FINGER007 CONNECTIONS)

RS422/RS232 converter is required to use RS422 communication between multiple FINGER007s and a host computer. Please follow the following instructions.

First, you have to connect all RS422 port of all FINGER007s in parallel.

- Connect RS422-TX(+) of one FINGER007 to RS422-TX(+) of another FINGER007.
- Connect RS422-TX(-) of one FINGER007 to RS422-TX(-) of another FINGER007.
- Connect RS422-RX(+) of one FINGER007 to RS422-RX(+) of another FINGER007.
- Connect RS422-RX(-) of one FINGER007 to RS422-RX(-) of another FINGER007.

Second, you have to connect one of RS422 port of FINGER007 to RS422/RS232 converter.

- Connect RS422-TX(+) of the one FINGER007 to RX(+) port of the converter.
- Connect RS422-TX(-) of the one FINGER007 to RX(-) port of the converter.
- Connect RS422-RX(+) of the one FINGER007 to TX(+) port of the converter.
- Connect RS422-RX(-) of the one FINGER007 to TX(-) port of the converter.
- Plug in the RS232 9pin connector of the converter to the COM1 or COM2 port of the PC.
- Install and run FINGER007 Application Software.

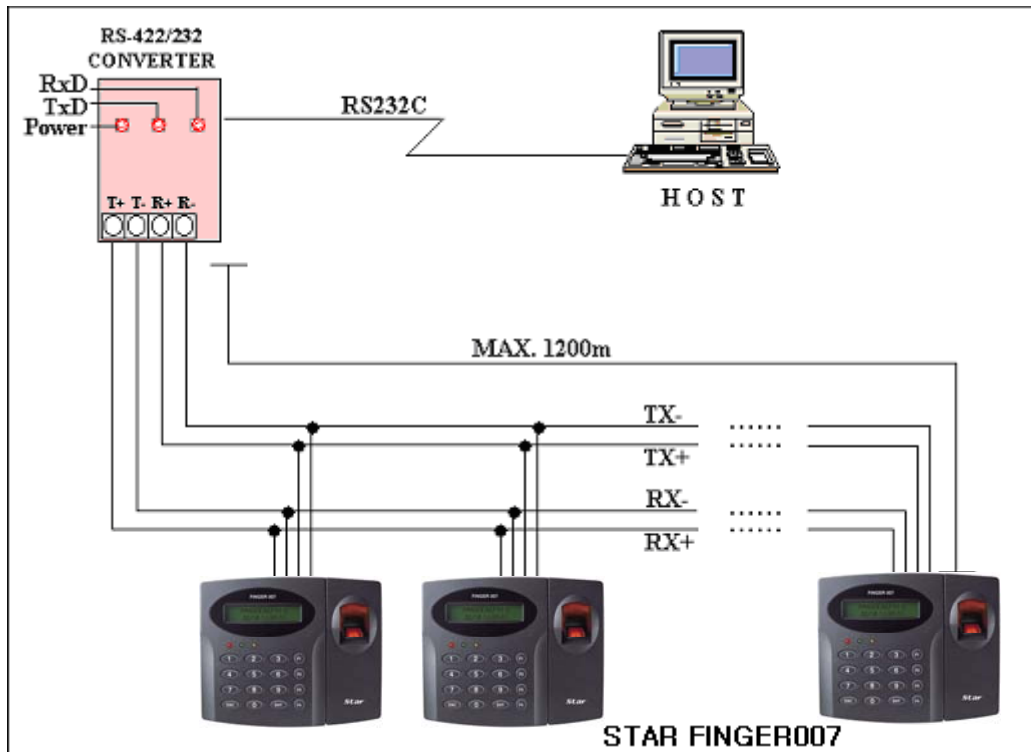

Figure : RS422 Communication between FINGER007s and Host Computer.

9.3 DIAL UP MODEM

Please, see the Software manual.

9.4 TCP/IP CONVERTER (EXTERNAL VERSION)

Please, see the Software manual.

10. Operation

10.1 NORMAL OPERATION

Power ON

When the Power is applied to FINGER007, the RED LED is turned on.

Fingerprint Identification

1. If registered card is read by the unit, red LED of fingerprint sensor is on.

At this time, you should put your finger and then remove your finger if red LED is off.

2. If fingerprint identification is done, card ID or authorization status appears on the LCD and fingerprint quality level also appears.

e.g.) [Q3]

3. Quality level appears from 1 to 5.

In case of Q1 or Q2, you can't use on identification mode (1:N) because of bad quality.

In case of Q3, Q4 or Q5, you can use on identification mode (1:N) because of good quality.

e.g) In case of fingerprint identification –Quality Level: 3, Card ID: 12300111

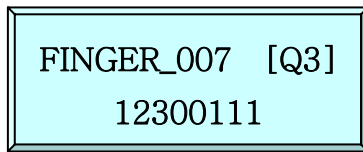

Registered Card Reading

When a registered card (or PIN) is read, the Door(Relay 1) will open for 3 seconds (Defaults) with the Green LED on.

Exit Button

To request for exit from the inside, an Exit Button(or Extra Reader) can be used.

The Door(Relay 1) will open for 3 seconds(Defaults) with the GREEN LED on.

Alarms (unregistered/password/fingerprint/time schedule/door ERROR)

When an unregistered card is read, wrong password is input, wrong fingerprint is input, over the time schedule, and access wrong door, the access is denied and the alarm(Relay 2) will be activated for 3 seconds(Defaults) with RED LED on.

10.2 DEFAULT SETTING

When you operate the FINGER007 first time or you initialize the FINGER007, the controller will setup all values defaults (factory settings). You can change the settings for desired application.

Please refer to the APPENDIX for the default setting values.

11. Setting Changes

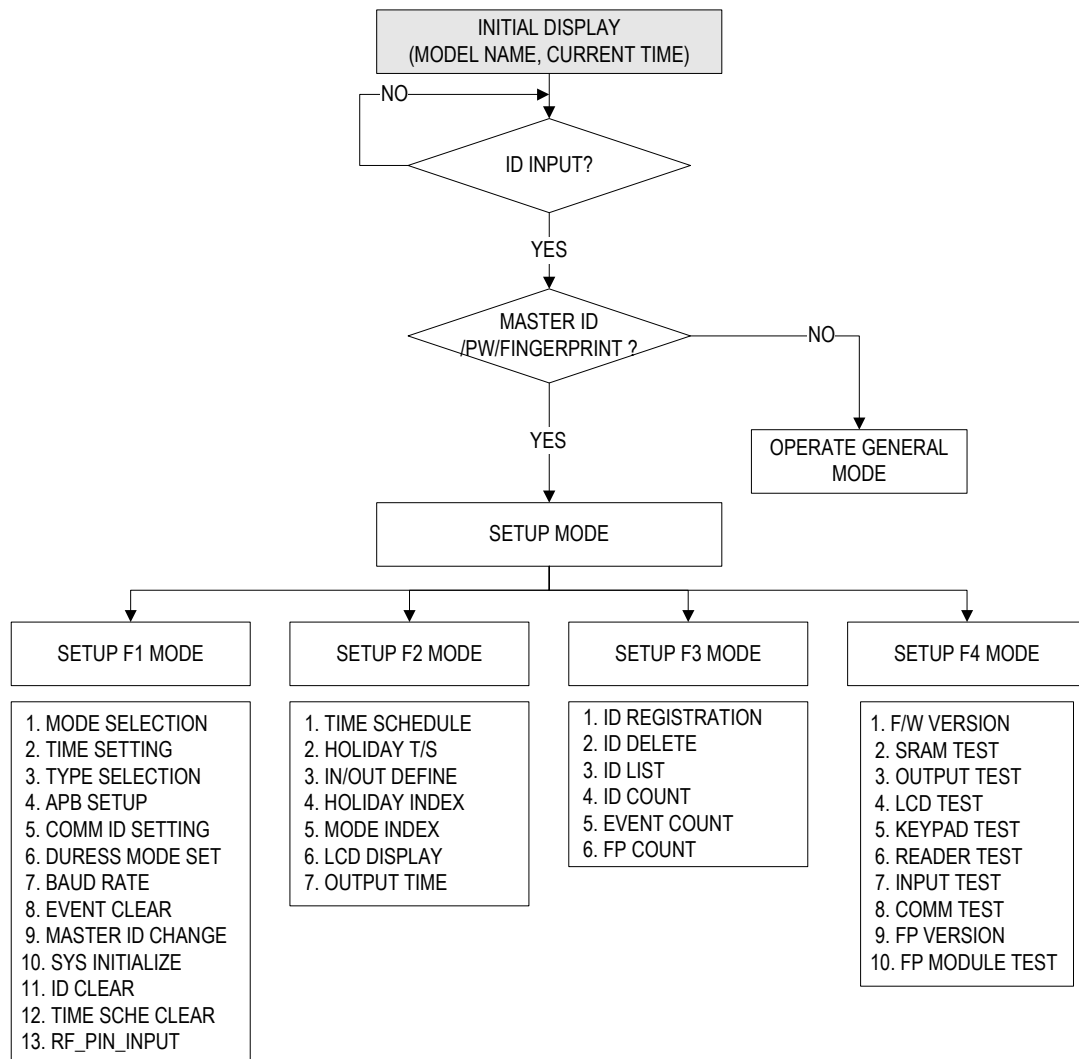

☞ To setup or to change the FINGER007 settings, you have to enter the SETUP MENU first. To do so, input Master ID(Default setting “00000000”), input Master P/W(Default setting “3141”) and input Master Fingerprint then you can get into SETUP MENU. There are 4 main SETUP MENU and you first get into [SETUP MENU F1]. You can move to other SETUP MENU by pressing <F1> key for [SETUP MENU F1], <F2> key for [SETUP MENU F2], <F3> key for [SETUP MENU F3] and <F4> key for [SETUP MENU F4]. There are several SUB MENU in the main SETUP MENU and you can scroll up and down the SUB MENU by pressing <4> and <6> key in the main SETUP MENU. If you press <ESC> key then FINGER007 will exit the SETUP MENU and return to normal operation. The Master ID for FINGER007SR is 10 times <0> key(Default setting).

11.1 SETUP MENU F1

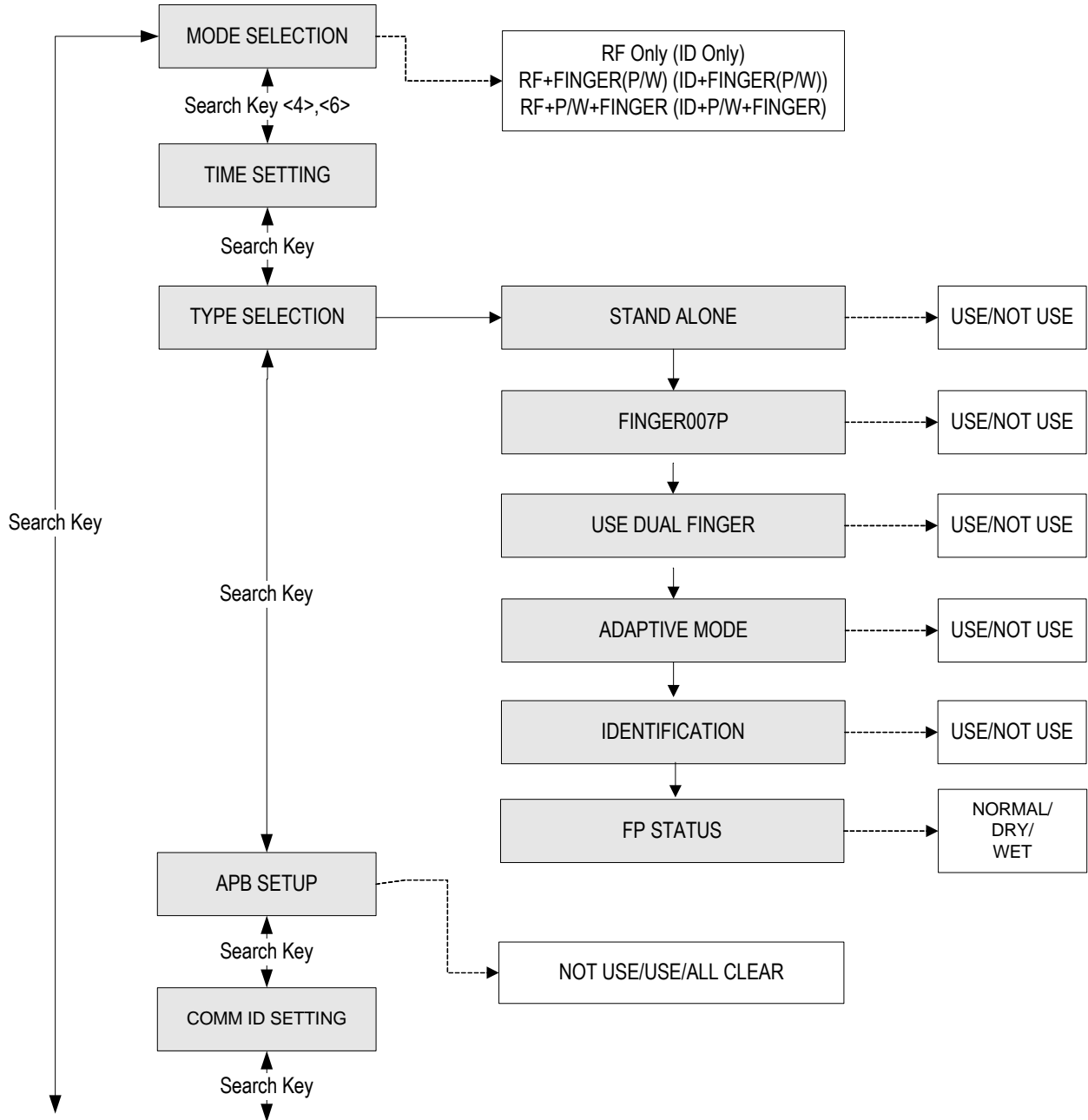

11.1.1 READER MODE SETTING

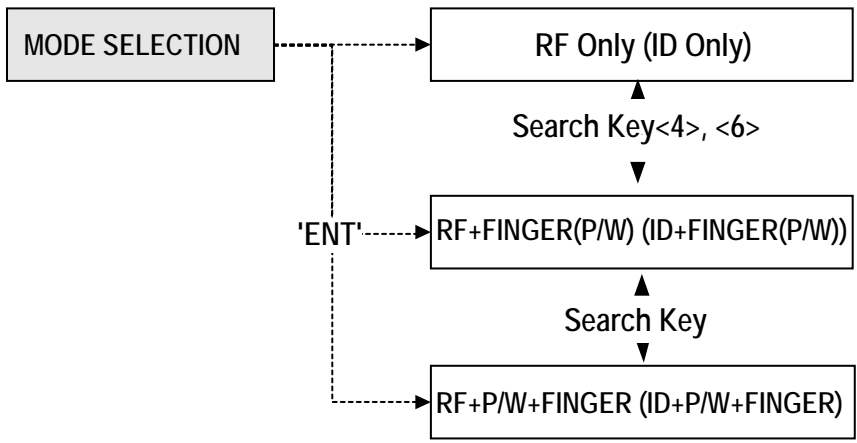

MODE SELECTION
 -->RF ONLY

MODE SELECTION
 -->RF ONLY

MODE SELECTION
 -->RF+FINGER(P/W)

MODE SELECTION
 -->RF+PIN+FINGER

This Menu is to select operating mode. You can choose whether to use password(or fingerprint) to each access or not. The lower line on the LCD indicates the current operating mode.
 Press <ENT> key to change the mode.

Then, this figure appears on the LCD, press <4> key or <6> key to toggle the mode, and finish selecting by pressing <ENT> key. For the next setting, use <4> and <6> keys.
 RF only : The door is accessible with the card(ID) alone.
 RF+FINGER(P/W): To access the door, the card(ID) and the fingerprint(P/W) is needed.
 RF+PIN+FINGER: To access the door, the card(ID) and password and fingerprint are needed.

11.1.2 TIME SETTING

TIME SETTING
 MM/DD hh:mm:ss

The lower line on the LCD indicates present time.
 To set time, press <ENT> key.

YYYYMMDDhmmssW
 █ _____

Enter the correct information of the year, month, date, hour, minute, second, day code in due order, then the setting is finished. If the input information is out of range, an error message appears on the LCD and the current time value is to be kept.
Day code
 1 : Sun, 2 : Mon, 3 : Tue, 4 : Wed, 5 : Thu, 6 : Fri,
 7 : Sat.
 EX) <200306071330253>
 →Tuesday, June 7, 2003 01:30:25PM.

11.1.3 TYPE SELECTION

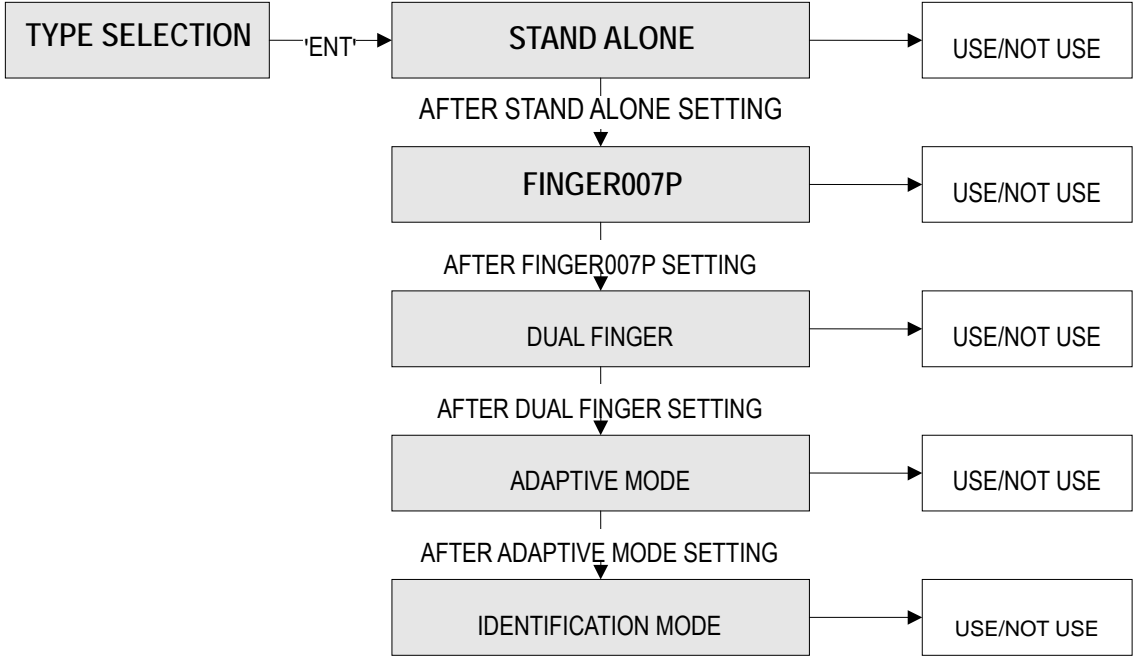

USE STAND ALONE?
 -->NOT USE

. You can select to use the device Stand Alone or not. Press <4> or <6> to toggle the mode, from <NOT USE> to <USE> or the reverse, and finish by pressing <ENT> key.
NOTE: When set to <USE> the system does not display the <event full> message.

USE FINGER_007P?
 -->NOT USE

. This menu comes after <STAND ALONE> setting.
NOTE: If you use FINGER007P, then you have to set this mode to <USE>.

USE DUAL FINGER?
 -->NOT USE

. This menu comes after <FINGER007P> setting.
NOTE: If you set Dual finger mode to 'USE ', you can register 2 different fingers for your ID so that if one finger is injured, you may verify your ID with the other registered finger.

USE DUAL FINGER?	No. of Template/Finger	Authentication Success Ratio	Recommended Authentication Mode
NOT USE	2 fingerprint storage templates for a single finger.	High	Identification Mode
USE	1 fingerprint storage template each for 2 different fingers.	Low	Verification Mode

USE ADAPTIVE MODE?
 -->NOT USE

. This menu come after <DUAL FINGER> setting.
NOTE: In ADAPTIVE MODE, scanning quality is better and scanning speed is slower than in normal mode. If you use the unit in a high temperature of over 40°C (104°F), you have to setting by <USE>.

IDENTIFICATION?
 -->NOT USE

☞ . This menu comes after <ADAPTIVE MODE> setting.
NOTE: In IDENTIFICATION MODE, you can use 1:N authentication. You can authenticate ID only with fingerprint and without PIN or Card input. In Identification mode, you have to press <ENT> before fingerprint certification.
 (FINGER007 (of V4.75 or higher) has a sensor(finger detect).
 * If not using Identification Mode, you're using Verification Mode.

FP STATUS
 -->NORMAL

☞ . After setting on Identification Mode, the unit moves automatically on FP STATUS mode.
NOTE: <NORMAL>: Default
 <DRY> Too dry area
 <WET> Too damp area

11.1.4 ANTI-PASS-BACK MODE SETTING

APB SETUP
 --> NOT USE

☞ . You can select whether the anti-pass-back(APB) mode is used or not. To change mode, press <ENT> key.
 (It only applies when the Door has Exit Reader)

APB SETUP
 --> NOT USE

☞ . Press <4> or <6> to toggle the mode, from NOT USE to USE or the reverse, and finish selecting by pressing <ENT> key.

APB SETUP
 --> USE

APB SETUP
 --> All Clear

NOT USE: Anti-pass-back mode is not applied.
 USE: Anti-pass-back mode is separately applied.
 All Clear: Once APB flag of all registered ID is applied, only 1time access is possible.
 From next, access not to a card reading is impossible.

11.1.5 COMMUNICATION ID(ADDRESS) DISPLAY

COMM ID SETTING

☞ . This is communication ID setting menu.
 To change the communication ID, press <ENT> key.

COMM ADDRESS
 00

☞ . The number on the LCD is the current communication ID(Device NO.) Press <ENT> key again to set a new communication ID.

COMM ADDRESS
01

☞. When the cursor is blinking, enter a new ID(Two Digit number), then the setting is completed. Possible ID is between 00 ~ 31 inclusive.

11.1.6 Setting Duress Mode

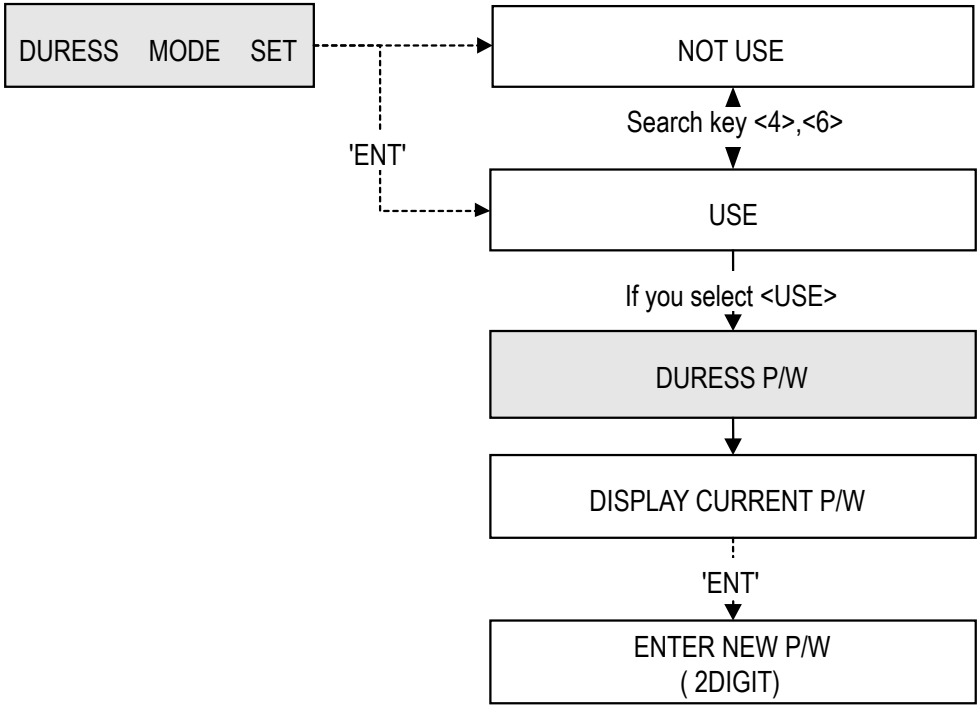

DURESS MODE SET
NOT USE

☞. You can select whether the Duress mode is used or not. To change mode, press <ENT> key.

DURESS MODE SET
--> USE

☞. If you select USE, then system display current DURESS P/W. To change P/W, press <ENT> key.

DURESS P/W
00

DURESS P/W
99

NOTE : You can setting duress output in setup menu F2(in/out define). In case of Duress, enter the 2 digit Duress Password and press <ENT> and open the door using general process. If you registered ID, then duress output will be generated.

11.1.7 BAUD RATE SETTING

BAUD RATE
9600

BAUD RATE
--> 9600

BAUD RATE
--> 19200

 FINGER007 supports 4800, 9600 and 19200 of baud rate and default setting is 9600bps. Wrong baud rate setting will cause communication errors and you have to set same baud rate to FINGER007 and host PC. If you have communication problem, please check followings;

- Check COMM ID of FINGER007 and host PC
- Check BAUD RATE of FINGER007 and host PC
- Check communication port and cable
- Check COM port setup of host PC

Parity: None, Data Bit: 8 bit, Stop Bit: 1 bit

To change the baud rate, press <ENT> key and select desired baud rate by pressing <4> or <6> key then press <ENT> key.

11.1.8 EVENT CLEAR

EVENT CLEAR

EVENT CLEAR
1 - YES, 0 - NO

 You can clear the event memory in this menu. Press <ENT> key then press <1> key to clear event memory or <0> key to cancel the operation.

※CAUTION : Before you clear the events, make sure that the stored events is not necessary to upload to the host PC otherwise you may lose important data.

11.1.9 MASTER ID CHANGE

MASTER ID CHANGE

CARD & Key Use
1-Card, 2-Key

 Press <ENT> key to change the current Master ID. You should use the new Master ID to access the SETUP MENU after you changed the Master ID.

Default Master ID/PW

FINGER007 : "00000000" <ENT> "3141"

FINGER007SR : "0000000000" <ENT> "3141"

Scanning ...

 FINGER007 is waiting for an RF card which is to be registered. The card number will appear with a beep as the card is read.

INPUT NEW MASTER
 [█]

☞ FINGER007 is waiting for a keypad which is to be registered.
 FINGER007 : 4 to 8 digits
 FINGER007SR: 10 digits
 ("0000000001" ~ "4294967295")

Put Master FP

☞ A fingerprint for the new Master ID is needed to be scanned.
 If there has been a Master ID already, the fingerprint of the ID should be scanned first.

Enter Password
 █

☞ Enter a new Master password(four digits) and finish changing Master ID

Master Card Registered

☞ The message indicates that changing Master ID has finished successfully, and you will soon return to the first screen of this menu.

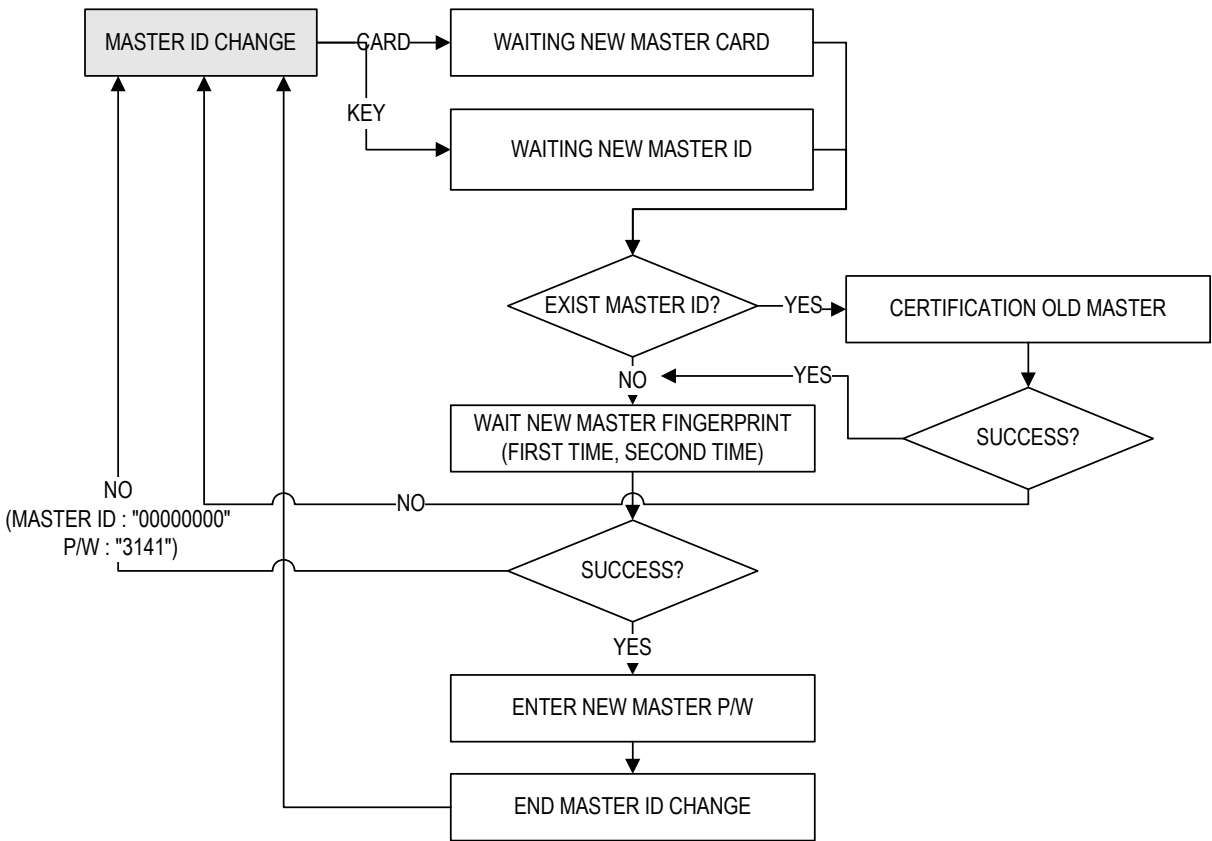

11.1.10 SYSTEM INITIALIZE

SYS INITIALIZE

Sys Initializing
 1 - Yes, 0 - No

System
 Initializing ...

☞ This operation will initialize the FINGER007. Press <ENT> key, if an initialization is needed. (First time installation or resetting in the event of a malfunction) After the initialization, FINGER007 will return to the setup menu.

※ CAUTION : Initializing will erase all stored data in the memory. (ID, EVENT, T/S, In/Out define, etc.)

11.1.11 CARD ID CLEAR

CARD ID CLEAR

Card ID Clear
 1 - Yes, 0 - No

☞ When you want to delete all User ID (Card ID), you can clear all User ID from the memory. Press <ENT> key then press <1> key to clear all User ID or <0> key to cancel the operation.

※ CAUTION :
 Before you clear all User ID, make sure that the registered User ID is longer used otherwise you may lose all registered User ID.

11.1.12 TIME SCHEDULE CLEAR

TIME SCHE CLEAR

Time Sche Clear
 1 - Yes, 0 - No

☞ When you want to delete all Time Schedule (01~10), you can clear all T/S from the memory. Press <ENT> key then press <1> key to clear all T/S or <0> key to cancel the operation.

※ CAUTION :
 Before you clear all T/S, make sure that the stored T/S is no longer used otherwise you may lose all stored T/S in the memory.

11.1.13 KEYPAD INPUT SETTING

RF_PIN_INPUT
 ENABLE

RF_PIN_INPUT
 --> DISABLE

☞ You can enable PIN(card number) to be input through the keypad, so that someone who doesn't carry RF cards with him can access the door. When it is disabled, accessing the door by keypad will be denied. Press <ENT> key to toggle the mode.

※ CAUTION: The default Master number, "00000000", must be replaced with a new Master card number before disabling keypad input, or you CANNOT access the setup menu again. In case of that, the only thing you can do is hardware initializina. Do not use this menu in FINGER007P.

11.2 SETUP MENU F2

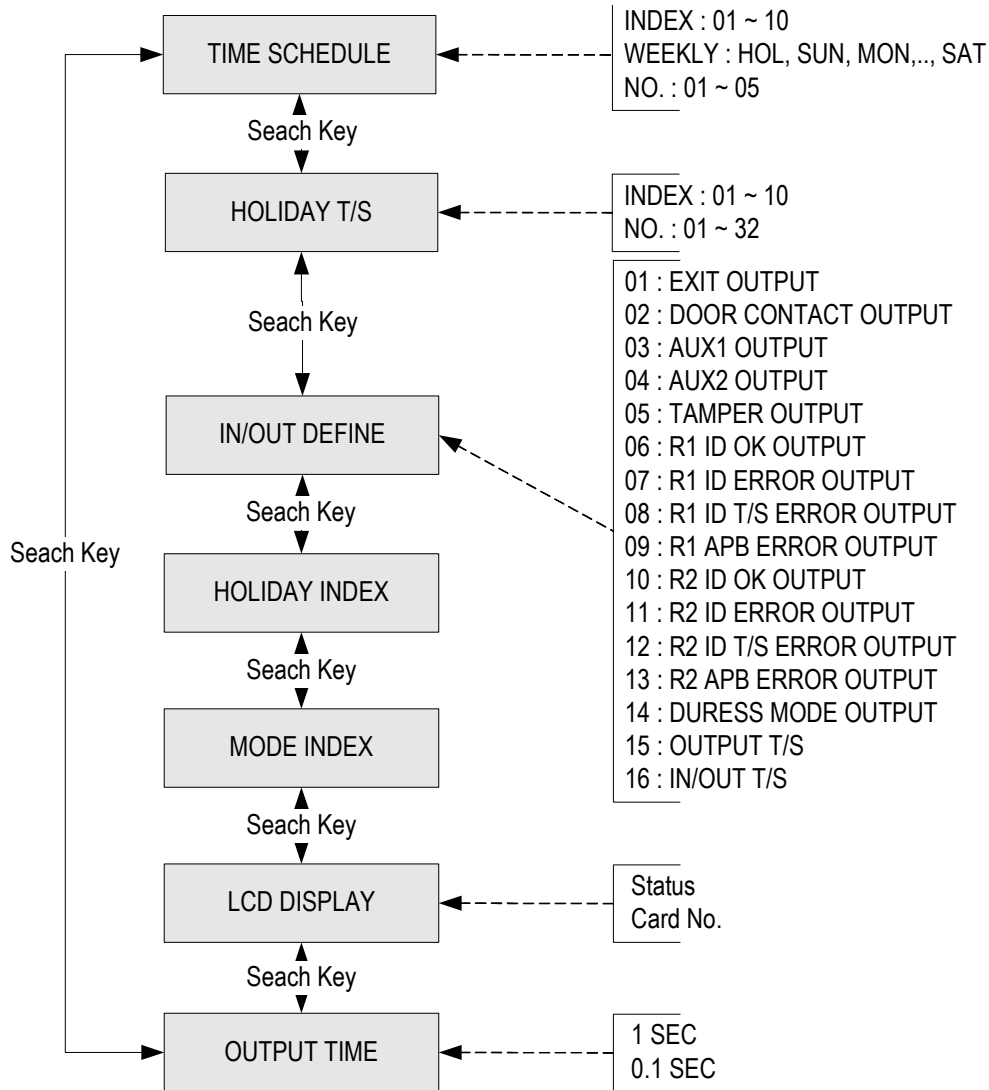

11.2.1 REGISTERING AND CHANGING TIME SCHEDULE

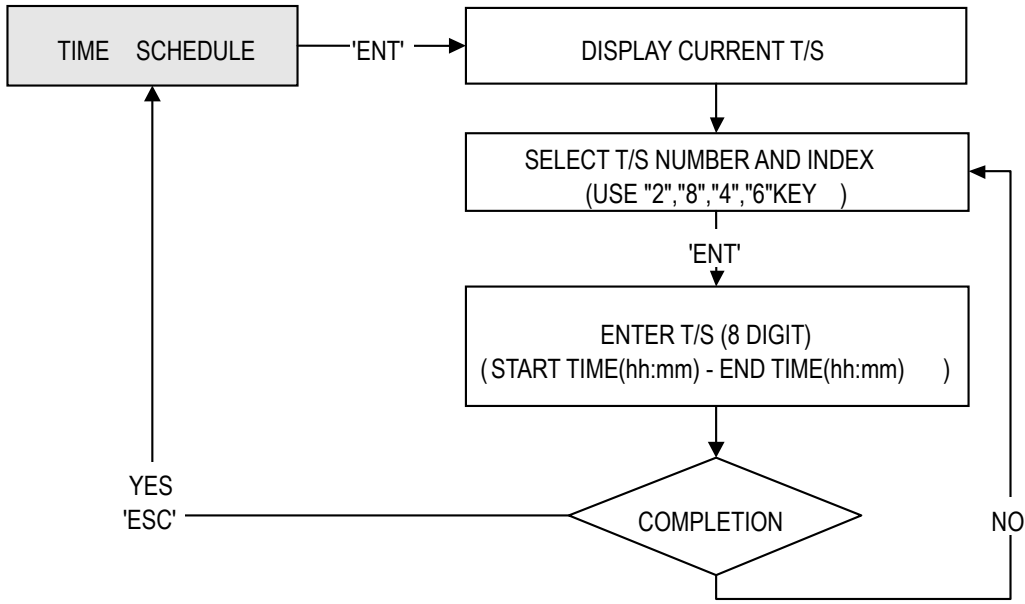

TIME SCHEDULE

☞ You may program time schedules to grant and restrict access for each user. There can be up to ten different schedules. A minimum of one schedule must be defined. If only one schedule is programmed the most common setting allows access for all users 24 hours / day. A time schedule can be programmed for each day of the week and holidays, and five shifts can be defined for each day. To set time schedules, press <ENT> key from this menu. If you want to set time schedules, press <ENT> key when this figure is displayed.

T/S : 01 HOL : 1
 00:00 - 00:00

☞ Press <2> key or <8> key to adjust the Time Schedule (T/S) number (1-10) and the day of the week (Mon-Sun and 'HOL'). Define which shift of the day (1-5), using the <4> key and <6> key. 'HOL' refers to specific holidays you will register. Press <ENT> key, and the cursor will blink, then enter the beginning time of the period, in the form of hour(2-digit):minute(2-digit) and the ending time in the same form. Then the lower line will indicate the defined period. For more schedules, repeat the process. To end time scheduling, press <ESC> key.

☞ Possible values for time scheduling

- 1) Time schedule number : 01 ~ 10 (Needed when IDs are registered)
- 2) A day of the week : MON, TUE, WED, THU, FRI, SAT, SUN, HOL
- 3) Index : 1 ~ 5(referred to the five periods of time of a day)

11.2.2 REGISTERING AND CHANGING HOLIDAY TIME SCHEDULE

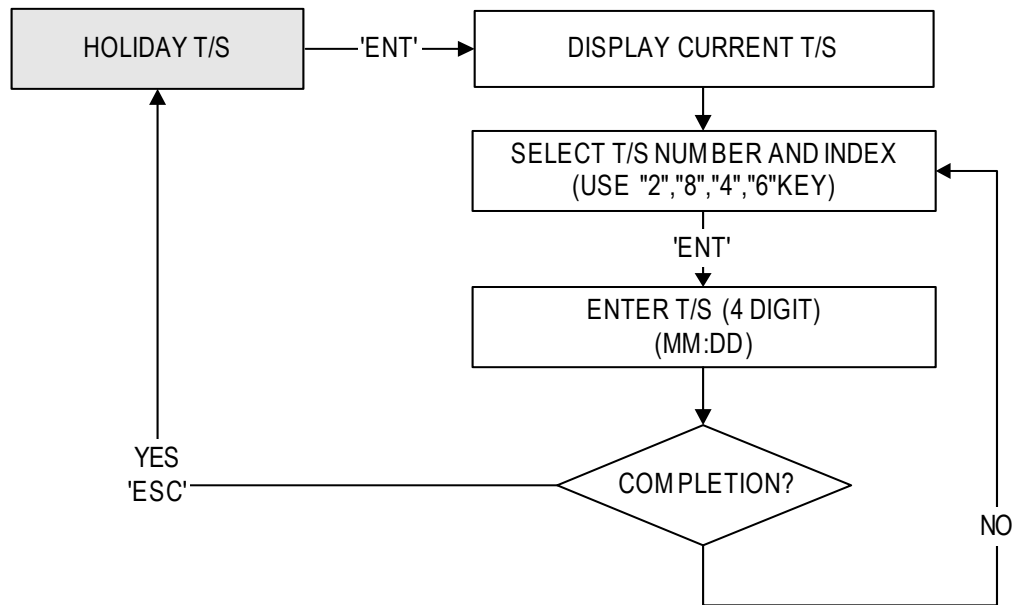

HOLIDAY T/S

HOL T/S : 01 #01
00:00

☞ You can register up to 32 specified "holidays," per year for each schedule setting. There can be 10 other registration sets created, meaning holidays can be set for up to 10 years. Press <ENT> to register the days.

☞ With <2> key and <8> key, select the date registration set number (1~10), and with <4> key and <6> key, select the index for the days (1~32). Then, press <ENT> key, and the cursor will blink, then enter the date, in the form of Month (1~12):date, Then the LCD will indicate the defined date. Now, a day has been registered. For further registration, repeat the process.

- ☞ 1) Holiday Time schedule(Date registration set) number : 01 ~ 10(10 years)
2) Index for the days : 01 ~ 32(32 days)

11.2.3 DEFINING OUTPUTS IN COMPLIANCE WITH INPUTS

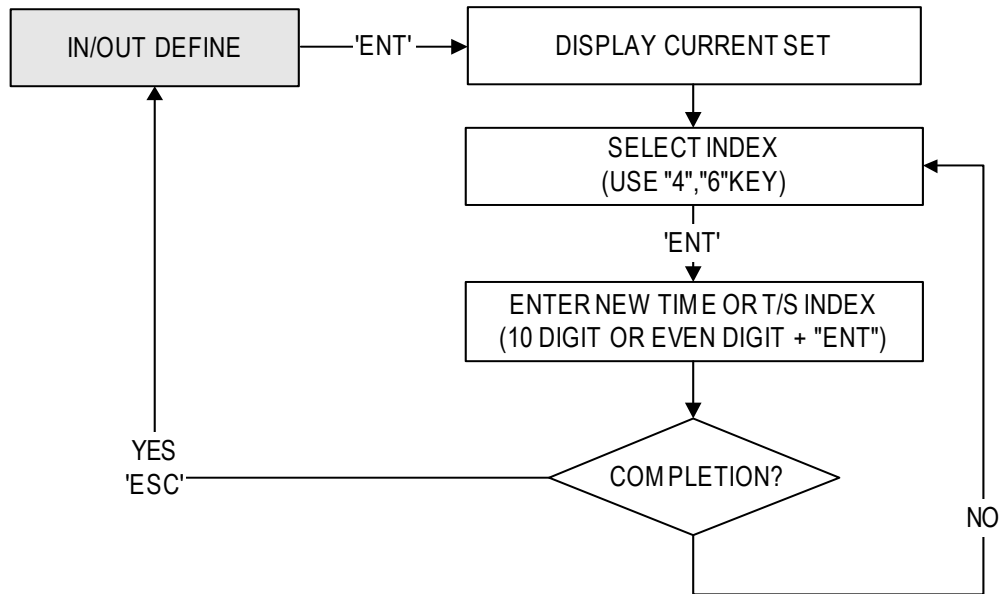

IN/OUT DEFINE

☞ You can program or deactivate each output to be generated and choose how long (in seconds) they will last. There are default values as seen in the table 2 below..

1. Exit Button
03 00 00 00 00

☞ Select input sources by changing index No. with the keys <4> or <6>, and press <ENT> key, and you'll see a cursor blinking at the first digit, from the left, of the five couples of digit, which corresponds to relay1, relay2, TTL1, TTL2 and buzzer, respectively. Then enter the delay times(refer to the table below) one by one. Now, an inputs/outputs definition has completed. For further definition, repeat the process. To end defining inputs/outputs, press <ESC> key, and you will see the first figure of the menu.

NOTE : The five couples of digit of [15] Output T/S and [16] Input/Output T/S are time schedule indexes.

11.2.4 HOLIDAY INDEX SETTING

HOLIDAY INDEX

T/S Index : 01
H/D Index : 01

☞ . Holiday Index is to link the Holiday Schedule (H/S) to Time Schedule. You can setup one of holiday index (01~10) to one of T/S index (01~10) so that the Holiday Time Code in the T/S can be applied for the Holidays in the T/S. Default H/D Index is '00' which means no holidays are applied to T/S. Select HOLIDAY INDEX menu and press <ENT> then select desired T/S INDEX (01~10) by pressing <4> or <6> key then press <ENT> key to input 2 digit H/D Index.

11.2.5 READER TIME SCHEDULE SETTING

MODE INDEX
00

MODE INDEX
05

☞ . If You setup RF+FINGER(P/W) operating mode (Refer to MODE SELECTION), you can apply Time Schedule for MODE INDEX. During the time period of Time Code in the T/S, FINGER007 will operate RF ONLY mode. And the rest of time period, FINGER007 will operate RF+FINGER(P/W) mode.
To apply this function, you have to setup Time Schedules (T/S) and Holiday Schedules (H/S). Select MODE INDEX then press <ENT> key. Enter 2 digit T/S index ('00' ~ '10').

11.2.6 LCD DISPLAY FORM SETTING

LCD DISPLAY
STATUS

LCD DISPLAY
→ CARD NO

☞ . This is LCD display setting menu. You can select whether LCD form is STATUS or CARD number.

- STATUS : Display status of reading ID.
- CARD NO : Display reading ID number.

11.2.7 OUTPUT TIME UNIT SETTING

OUTPUT TIME
1 SEC

OUTPUT TIME
→ 0.1 SEC

☞ This menu is to define time unit of 5 output ports.
 1SEC: Define time of output by second in the in/out define.
 0.1SEC : Define time of output by 0.1 second (100ms) in the in/out define.
 Ex) In order to have the relay 1 operate for 3 second, responding to the exit button input, set as follow.
 - Define 1 Exit & Relay as "03" in IN/OUT define
 - Define the OUTPUT TIME SET as 1 SEC.
 Ex) In order to have the relay 1 operate for 0.3 second, responding to the exit button input, set as follow.
 - Define 1 Exit & Relay as "03" in IN/OUT define
 - Define the OUTPUT TIME SET as 0.1 SEC.

11.3 SETUP MENU F3

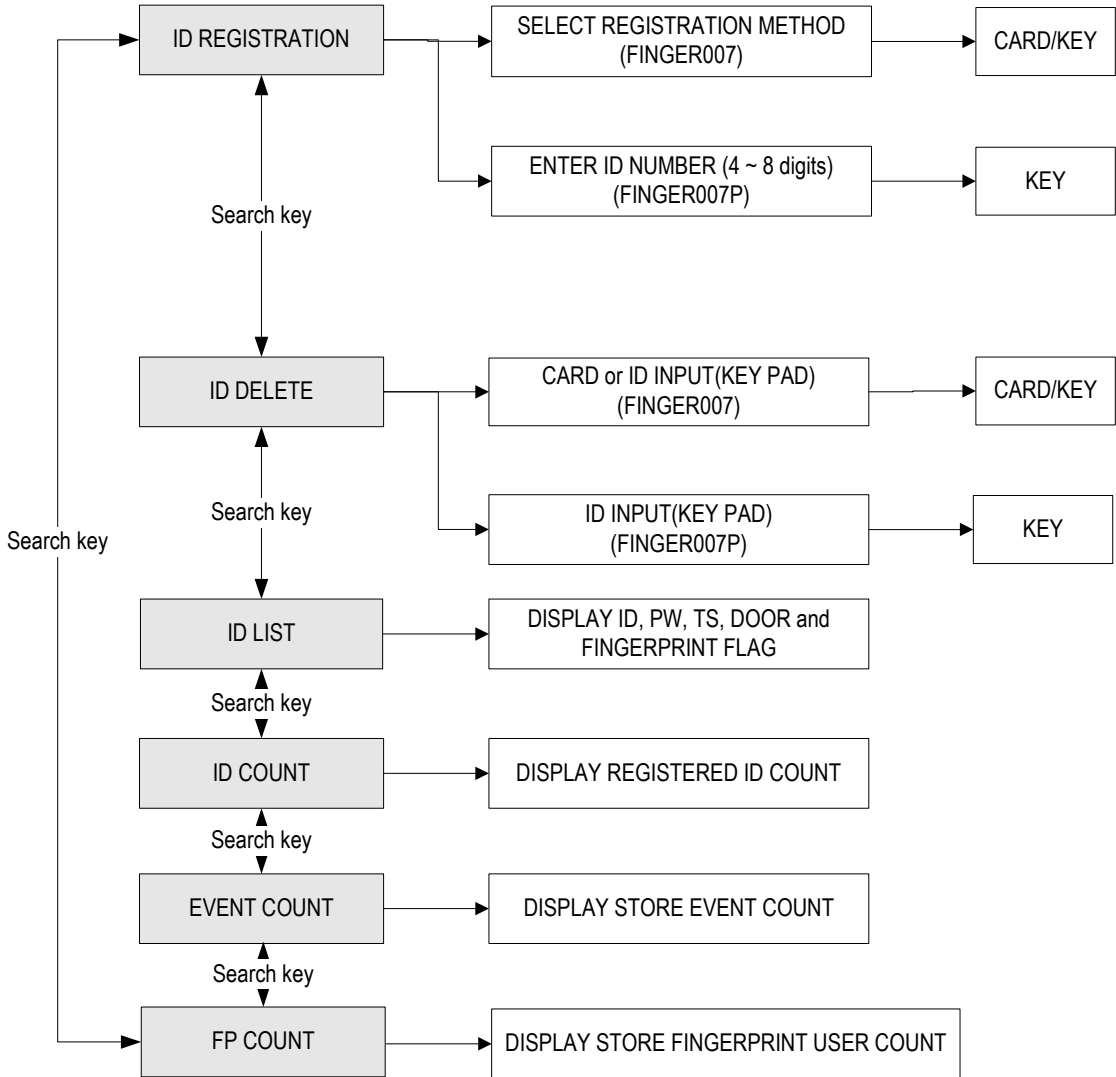

11.3.1 CARD REGISTRATION

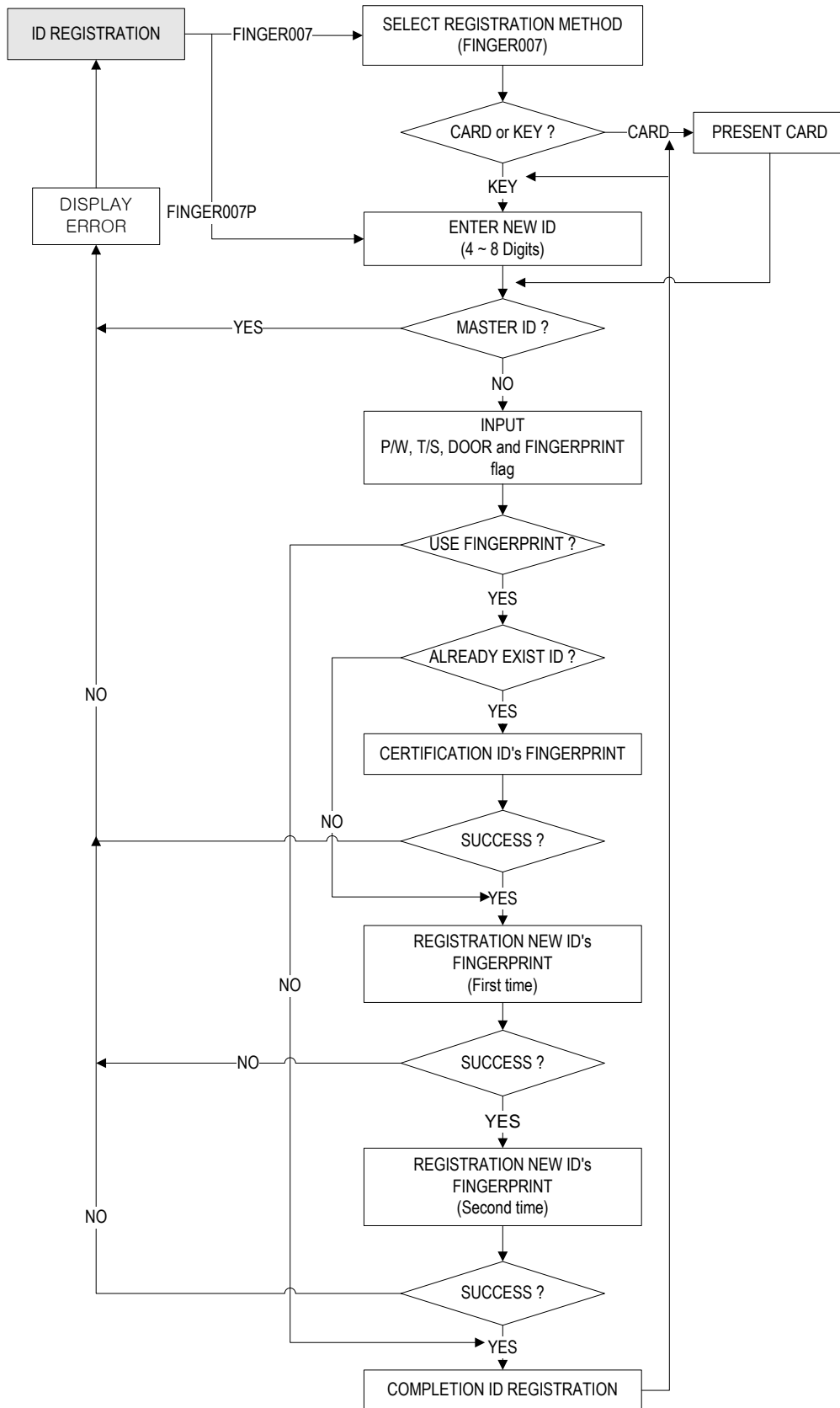

ID REGISTRATION

☞ ID number is registered in the FINGER007 by RF cards or through the keypad. For RF cards, Press <1> key, the keypad, <2> key, or you can quit the registration by pressing <ESC> key.

CARD & Key Use
 1 - CARD, 2 - Key

FINGER007 - Over V4.60 : 4 ~ 8 Digits.
 Under V4.60 : 4 Digits.
 FINGER007SR - 4 ~ 8 Digits.

Put ID CARD
 Scanning ...

☞ In case register by RF card, FINGER007 is waiting for an RF card which is to be registered. And In case register by keypad, you can register 4 ~ 8 digits ID.

Key Input ID
 → █ _____

* **CAUTION** :
 Under V4.60 : In case register by keypad, you have to enter only 4digits ID.

XXXXXXXX
 PW____TS__RD_FP_

☞ This figure appears, indicating the ID number you just entered on the upper line, and you are to enter the following information for the ID number : Four-digit password, two-digit Time Schedule number, Reader number(see the NOTE below) and FP flag(enter <1> to register a fingerprint, <0>, not to.). If you enter <0> for the FP flag, the message 'ID Registered' will be shown for a moment and the controller waits for another PIN number to be input. You can register other PINs in the same way. Press <ESC> key to quit the registration. (You can change the TS, the RD and the FP flag in the same way as the new registration)

XXXXXXXX
 ID Registered

To Register FP
 Put Your FP On ..

☞ If you enter <1> for the FP flag to register a fingerprint for the ID number, you'll see this message showing and the red light flashing in the fingerprint input window. As the fingerprint should be scanned twice, Put a finger to the window, according to the message displayed, lift the finger off briefly and put it again.

Lift and Put FP
 Waiting ...

NOTE:

1. The fingerprint registration needs two a little different images of a fingerprint. For that reason, after the first scan, the finger must be lifted off briefly.
2. When a ID number using fingerprint is re-registered for changing options, the current fingerprint is needed to be scanned.

ID Registered
 [Q#1:] [Q#2:]

Display quality level of registered fingerprint

☞ . Quality level of fingerprint appears from Q1 to Q5.
 When you register fingerprint, you should register two fingerprints.
 [Q#1: __] appears quality of first registered fingerprint.
 [Q#2: __] appears quality of second registered fingerprint.
 In case of Q1 or Q2, you can't use identification mode (1:N) because of bad quality.
 In case of Q3, Q4 or Q5, you can use identification mode (1:N) because of good quality.

- 1) PW(password): The password used in RF + fingerprint(password) and RF + password + fingerprint mode.
- 2) TS(Time schedule)
 00: Anytime accessible
 01 ~ 10 : Accessible according to each T/S index
- 3) RD(Reader code)
 1 : for using reader 1 alone
 2 : for using reader 2 alone,
 3 : for using both reader 1 and 2.
- 4) FP(Fingerprint flag)
 1 : To register a fingerprint for the ID number being registered.
 (If the ID number has a fingerprint already, in case of re-registration, the current fingerprint should be scanned first.)
 0 : When the ID don't need a fingerprint registered.
 If the controller is set to operate in RF+FINGER(P/W) or RF+P/W+FINGER mode. it will operate in RF+P/W(Password)mode.

11.3.2 ID DELETE

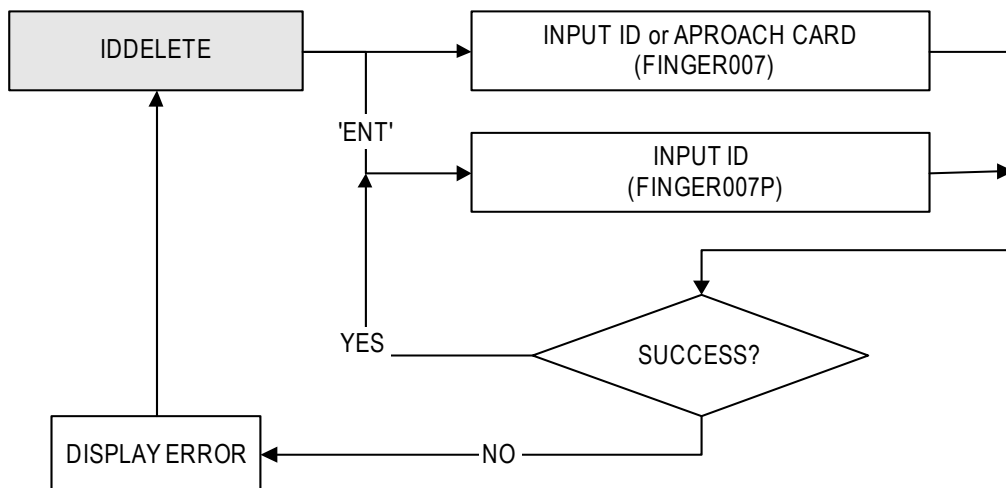

ID DELETE

☞ . This is registered ID Deletion menu.
 To delete some registered IDs, press <ENT> key.

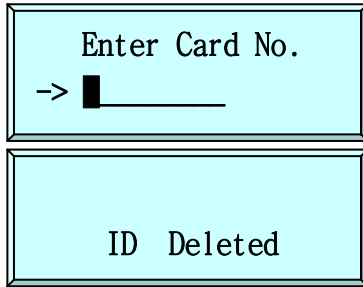

Enter the ID number or approach card that you want to delete.

11.3.3 ID LIST

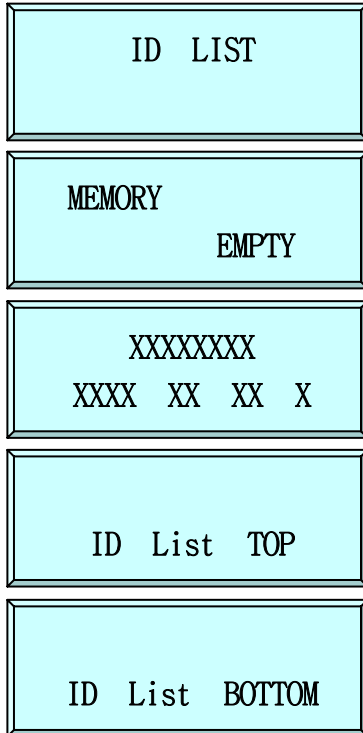

☞ If you want to see the list of registered user ID, press the <ENT> key in this menu. "MEMORY EMPTY" message will be displayed when there is no registered user ID.

From four to eight digit user ID, 4 digit password, the applied T/S, reader code and fingerprint flag are displayed on the LCD, and you can scroll up and down the list by pressing <4> and <6> keys. Press <ESC> key to return to the setup menu.

"ID LIST TOP" message will be displayed first when the first registered user ID is displayed on the LCD. "ID LIST BOTTOM" message will be displayed first when the last registered user ID is displayed on the LCD.

11.3.4 REGISTERED ID COUNT

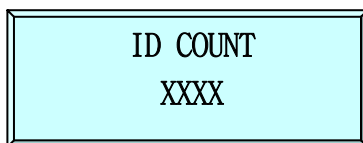

☞ This menu displays the total number of registered user ID count. It automatically counts when you register or delete user ID.

11.3.5 STORED EVENT COUNT



☞ This menu displays the total number of stored event count.

11.3.6 STORED FP COUNT

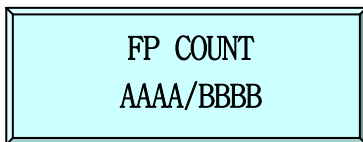

☞ This menu displays the total number of stored fingerprint count.

AAAA: currently registered fingerprint users
BBBB: maximum fingerprint users
 e.g. 1000 / 2000 / 4000 fingerprint users

11.4 SETUP MENU F4

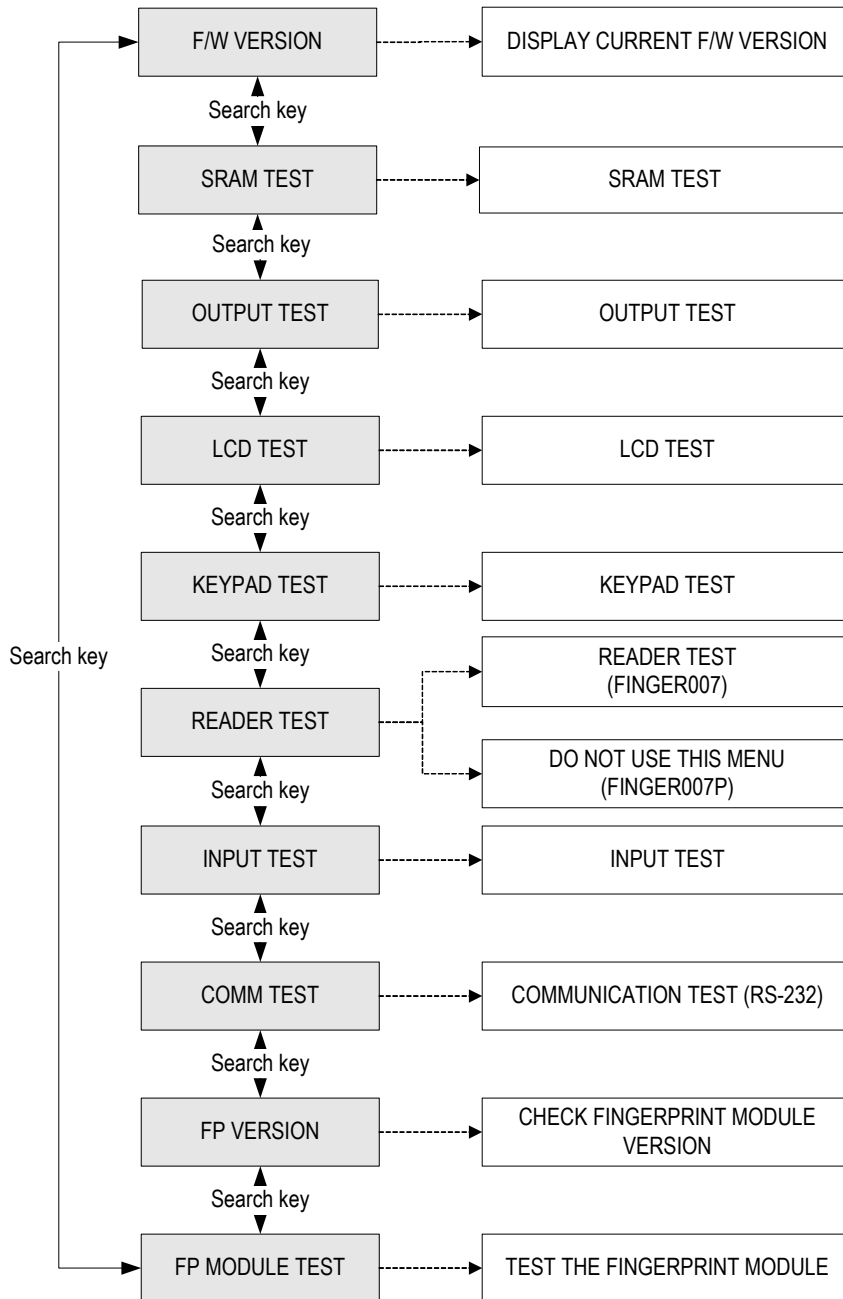

11.4.1 VERSION CHECK

F/W Version
X.XX

The version of the controller's firmware is displayed on the LCD. Press <4> or <6> key to look for other menus of setup menu F4.

11.4.2 SRAM TEST

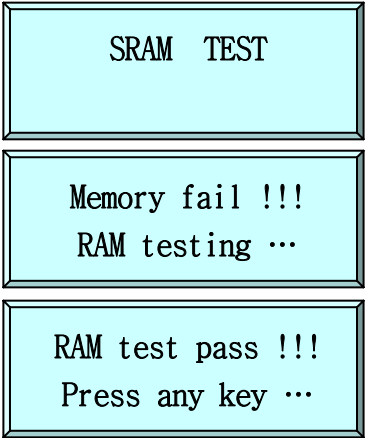

. To test the SRAM memory, press <ENT> key.

If the SRAM has problems, LCD will show the memory block number with “Memory fail!!!” message. In this case, you have to contact technical support.

If the SRAM is working properly then LCD will show “RAM test pass!!!” message.

11.4.3 OUTPUTS TEST

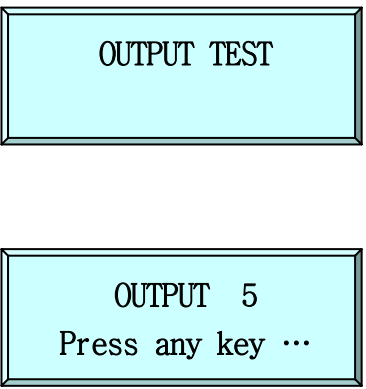
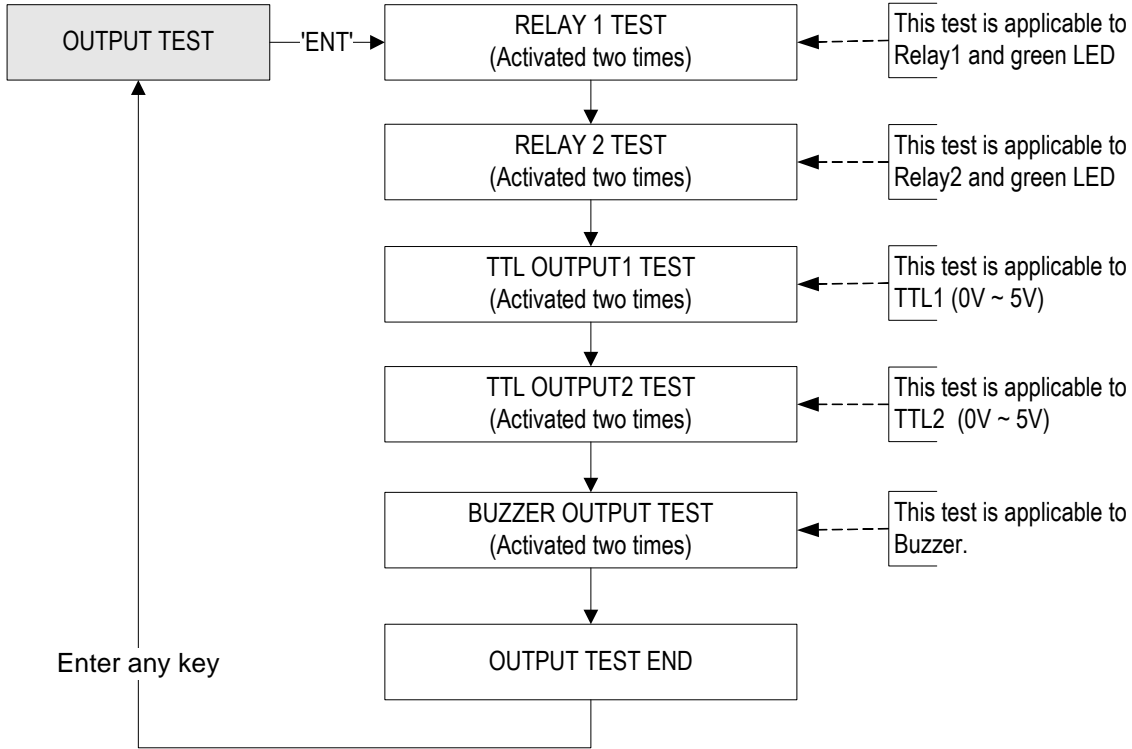

. To test the output performances, press <ENT> key.

If the output performance has no problems, the test will proceeds as follows :

First, the green LED blinks twice as the relay is being shorted and opened twice. The relay ticktack as it works, you can hear the sound.

Second, the yellow LED blinks twice as the relay is being shorted and opened twice. The relay ticktack as it works, you can hear the sound.

11.4.8 COMMUNICATION TEST

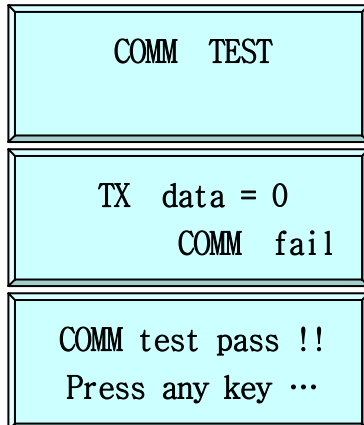

☞ . To test performance of input ports, press <ENT> key.
(Before this communication test, connect the RS-232 RX, TX wires to each other.)

If there is a problem with the communication performance, check connections and try again. As the test proceeds, you can see the characters being transmitted and received. Finally LCD display communication test pass message.

11.4.9 FP VERSION

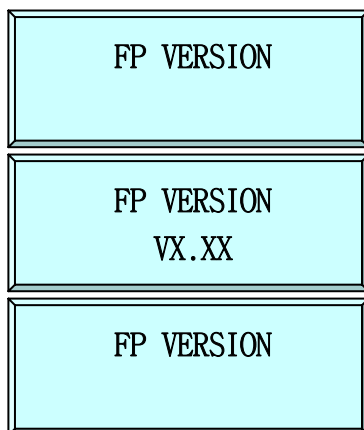

☞ . To check what version of Fingerprint(FP) module is installed to the device, press <ENT> key.

The current version of the installed fingerprint module will be displayed for a while. (e.g. V1.35)

11.4.10 FP MODULE TEST

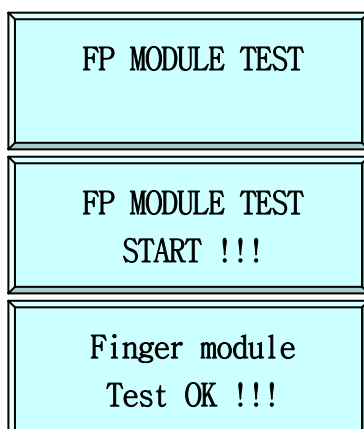

☞ . To ensure that the installed fingerprint module is operating without any problem, press <ENT> key.

On pressing <ENT> key, the 'FP MODULE TEST START!!!' message will appear and then the fingerprint sensor will be lit for a second. If the test is successful, the 'Finger module Test OK!!!' message will be displayed on the screen.

12. APPENDIX

A. THE RELATION BETWEEN INPUT AND OUTPUT(DEFAULT)

1. The relation between input and output

Index No	Relay#1	Relay#2	TTL1	TTL2	BUZZER
[1] Exit Button	03	00	00	00	00
[2] Door Contact	00	03	03	03	03
[3] AUX 1	00	03	03	03	03
[4] AUX 2	03	00	03	03	03
[5] Tamper S/W	00	99	99	99	99
[6] Reader1 ID OK	03	00	00	00	00
[7] Reader1 ID Error	00	03	00	00	00
[8] Reader1 ID T/S Error	00	03	00	00	00
[9] Reader1 APB Error	00	03	00	00	00
[10] Reader2 ID OK	03	00	00	00	00
[11] Reader2 ID Error	00	03	00	00	00
[12] Reader2 ID T/S Error	00	03	00	00	00
[13] Reader2 APB Error	00	03	00	00	00
[14] DURESS MODE	03	00	03	03	00
[15] OUTPUT TIME SCHEDULE	00	00	00	00	00
[16] INPUT TIME SCHEDULE	Exit	Contact	AUX 1	AUX 2	Tamper
	00	00	00	00	00

- * Index No. [1] ~[14] : The value indicates operation time (second) of each output for the input signal.
- * Index No. [15] : The value indicates time schedule code (index) that each output operation is to be applied.
- * Index No. [16] : The value indicates the time schedule code (index) that each input:1(Exit button) ~ 5(Tamper S/W) operation is to be applied.

B. TROUBLE SHOOTING

<p>☞ Broken or abnormal letters show on the LCD, when powered on.</p>	
Cause	Of troubles of its battery in charge of the internal back-up or of circuits near around
Solution	<ol style="list-style-type: none"> 1. Initialize the controller referring “hardware initialization of the manual” 2. Set the current time in Set-Up menu of F1 and turn its power off and on again. 3. If the problem remains after performing 1, 2 of the above, please contact designated service center.
<p>☞ Unable to enter set-up mode with MASTER ID (default value: ‘00000000’) and P/W (default value: ‘3141’) cf. In case FINGER007SR, master ID consists 10digits character. (Default ID “0000000000”)</p>	
Cause	Of internal element error, of unconsciously changed Master ID or of Set-up error
Solution	<ol style="list-style-type: none"> 1. Check Master ID and Master P/W. Try changing the RF_PIN_ENABLE setting to “ENABLE” through the application S/W. Try changing the Master ID and P/W through the application S/W. 2. When it is not feasible, initialize the unit in the light of the manual. Check Backup BAT S/W (Mount hole in the reverse side. Of V4.70 or higher) - It must be placed “ON”. * Note that all the value will be set to default, including the IDs after initializing. 3. If the trouble remains after the procedure above, contact a designated service center.
<p>☞ Randomly changed value of in/out define from previously setting value after power reset.</p>	
Cause	Discharge of RAM Back-Up battery problem during the main power off.
Solution	<ol style="list-style-type: none"> 1. Check Backup Battery S/W : It must be placed ON. (Of V4.70 or higher) 2. Check if the voltage of Back-Up Battery is over 3.6V.. 3. If it is over 3.6V, make initialization process as below. <ul style="list-style-type: none"> - Turn off the system power and connect 3 wires (pink, cyan and black(GND)). - Turn on the system power. Then you can enter system initialization mode. Enter <1> key, then system is initializing. - After initializing, keep the main power on more than 5 days. * Aware that all the setting value be back to the default value and data memory be clear. (ID data clear/Event data clear/ Time Schedule data clear etc.) 4. If after all the above, the problem remains, please contact a designated service

	center.
☞ "ACCESS DOOR ERR" message shows when the RF ID card is read.	
Cause	Incorrect user setting or false of internal circuit.
Solution	<ol style="list-style-type: none"> 1. If it is of properly operating unit before, there has been electric shock that damaged internal memory and data. Please initialize the unit as instructed in the manual. 2. Check if ID information is put incorrectly during its registration. <ul style="list-style-type: none"> * Register ID again checking the following points. <ul style="list-style-type: none"> - Since the controller has two reader ports, define "RD" – door for the user to be allowed to access. <ul style="list-style-type: none"> Reader1 only (Main reader): "1", Reader 2 only (Extra reader): "2", Reader 1 & 2 both: "3" - If RD is set as "1", only when the card is read at reader 1, the door opens but not at reader2. If it is read at reader 2, "ACCESS DOOR ERROR" message shows. - If RD is set as "2", only when the card is read at reader 2, the door opens but not at reader1. If it is read at reader 1, "ACCESS DOOR ERROR" message shows. - If RD is set as "3", reader 1 & 2 both opens each door. 3. Use software for time schedule setting in case it is connected to PC as the software manual. 4. If the trouble remains after checking the above, contact a designated service center.
☞ "SCHEDULE ERROR" message shows when RFID card is read.	
Cause	Error in RFID card registration, time schedule setting or the system itself.
Solution	<ol style="list-style-type: none"> 1. If it is of properly operating unit before, there has been electric shock that damaged internal memory and data. Please initialize the unit as instructed in the manual. 2. Check if ID information is put incorrectly during its registration. <ul style="list-style-type: none"> * Register ID again checking the following points. <ul style="list-style-type: none"> -In order to restrict access of the ID user for specific time zone as instructed in the manual, register time schedule in advance and apply the time schedule code(1~10) in the registration of the user ID. - In order to allow the user to access at all times put "00". 3. Use software for time schedule setting in case it is connected to PC as the software manual. 4. If the trouble remains after checking the above, contact a designated service

	center.
☞ A valid card became unregistered after batch-downloading IDs from PC.	
Cause	Wrong procedure during download, or a component defect.
Solution	<ol style="list-style-type: none"> 1. The card ID might be registered only to the controller and not registered in PC. The process of downloading IDs, FINGER007 first erase the ID memory of the unit, therefore if the IDs from the PC didn't contain the card ID, this can happen. 2. Check whether the card ID is registered in PC 3. If not, please register the number and try downloading again. <p>If the trouble remains after the procedure above, contact a designated service center.</p>

☞ The controller does not communicate with PC.	
Cause	Defective cable is used, errors in wiring, an error in setting COMM ID of the controller, or damage on the communication port (either on PC side or on the controller side).
Solution	<ol style="list-style-type: none"> 1. Please, check the settings of the application S/W and the controller. <ul style="list-style-type: none"> - Check the controller's COMM ID is listed on the application S/W. - Set the different COMM ID when two or more controllers are installed. - Check the communication speed(Default 9600bps) is the same as the setting on the S/W. - Make sure that the PC's COM port is set correctly on the S/W. - The parameters at the S/W should be set as follows. <ul style="list-style-type: none"> Parity bit : NONE Data bit : 8bit Stop bit : 1bit 2. Check the line connection for communication

RS232		RS422(Single Drop)		
FINGER007	PC	FINGER007	RS232/422 Converter	PC
RX	TX	RX(-)	TX(-)	The RS232 cable from the converter.
TX	RX	RX(+)	TX(+)	
GND	GND	TX(-)	RX(-)	
		TX(+)	RX(+)	
RS422(Multi Drop)				
FINGER007	FINGER007	RS232/422 Converter		PC
RX(-)	RX(-)	TX(-)		The RS232 cable from the converter
RX(+)	RX(+)	TX(+)		
TX(-)	TX(-)	RX(-)		
TX(+)	TX(+)	RX(+)		

3. In case of setting RS422 communication, recommend to use line-end resistors of 120 Ohm between the RX(+) and RX(-) lines and between the TX(+) and TX(-) lines, and apply the same resistors to the converter RS422 lines. Consult a service center or an electric technician if you cannot be sure how to do it.
4. When a multi-drop communication doesn't work, test one-by-one communication first.
5. If the trouble remains after the procedure above, contact a designated service center.

🔊 Keep making buzzer sound: "beep~ beep ~ beep" or "beep~~~~".

Cause	Error in installation, door status or internal circuits.
Solution	<ol style="list-style-type: none"> 1. Check the door status. It occurs in case that the door is opened over 20 sec after the proper door open time. 2. Check the door contact sensor type: it should be NO type. 3. Check in "IN/OUT DEFINE" of F2, the fifth Time schedule code(01~10) value of 15 output T/S. If the time schedule code is set between 01-10 and if the present time is included in the schedule. If it is set to unintended value, change it to "00" (Programmable via PC software) 4. If the trouble remains after checking the above, contact a designated service center.

<p>☞ The extra reader seems to read cards, but the controller does not respond or does not respond properly, such as displaying wrong card numbers in the reader test mode.</p>	
Cause	Reader defect, wiring error between the reader and the controller, or the electric noises around.
Solution	<ol style="list-style-type: none"> 1. Be sure that the reader reads the card ID when you present a card. 2. Be sure that the reader format is correct. 26bit Wiegand or 34bit Wiegand for FINGER007SR. 3. Check the wiring between the reader and FINGER007. <ul style="list-style-type: none"> - Check the wires of Wiegand data lines D0 and D1 which is connected correctly. - Connect the controller ground to the ground wire of the reader and it is recommended to connect them to an earth ground. 4. Using oscilloscope, check the shape of signals from the reader at the controller's side. When noises are shown on the signals, it is recommended to use shielded wires and the unused wires to the common ground. You can use repeaters, also. 5. Check the maximum cable length, which may be indicated on the reader manual. 6. If the trouble remains after the procedure above, contact a designated service center.
<p>☞ No problem with accessing by cards, but cannot access with the PIN input.</p>	
Cause	An error in Setup or possible component defect.
Solution	<ol style="list-style-type: none"> 1. Check whether a beep sound is generated when you press a key. When it is, the problem may be an error in setup. Proceed followings. <ul style="list-style-type: none"> - Enter the Master ID("00000000" default), P/W("3141" default) and Fingerprint to enter the Setup mode. (Note that the default Master ID for FINGER007SR is 10 times <0>, "0000000000".) - Press <F1> key. - 'MODE SELECTION' will appear on the LCD, then use the key <6> to choose 'RF_PIN_INPUT' and select 'Enable' as wanted. 2. When there is no beep sound or already enabled Key-in functions, contact a designated service center.

<p>☞ "Fingerprint error" shows in the LCD repeatedly during fingerprint registration.</p>	
Cause	Of that fingerprint is damaged, fingerprint is extremely dried or the fingerprint module is defective of the device.
Solution	<ol style="list-style-type: none"> 1. Of fingerprint registration, it read a fingerprint twice. If the first one and the second one are perfectly accord, its registration fails. After the first fingerprint reading, take the finger out and put again on the fingerprint reading window. 2. If the fingerprint is extremely dry or seriously damaged, it can not find its specifications. Of version 4.00 or over, get into the setting mode, F1, TYPE SLECTION and change ADAPTIVE MODE "USE" and then try again its fingerprint registration. (ADAPTIVE MODE "USE" provides more delicate reading of fingerprint but it delays a little more than normal.) 3. If the problem remains after performing 1, 2 of the above, it could be of fingerprint module defect or the device defect, please contact IDTECK service center

<p>☞ "Door Closed"& CONTACT MASTER" it shows on LCD with buzzer sounds after card reading.</p>	
Cause	Of setting error, P/W deletion, defect of internal elements
Solution	<ol style="list-style-type: none"> 1. Check the communication status. If the communication of the device with PC is normal and this problem occurs, check if the yellow LED is on in normal. If normally the yellow LED is ON, the door is locked by output time schedule setting. 2. If it is case of "1" check OUTPUT T/S or reinitialize the device. If the problem remains after performing it, please contact IDTECK service center. 3. If it is not the case of "1", no communication, its yellow LED light off, it is of saved P/W deletion. Please contact IDTECK service center. 4. Of V4.5 or higher, in case of "3" it shows message "CONTACT IDTECK" WWW.IDTECK.COM with buzzer sound when the power is turn on.

13. FCC Registration Information

FCC REQUIREMENTS PART 15

Caution: Any changes or modifications in construction of this device which are not expressly approved by the responsible for compliance could void the user's authority to operate the equipment.

NOTE: This device complies with Part 15 of the FCC Rules.

Operation is subject to the following two conditions;

1. This device may not cause harmful interface, and
2. This device must accept any interference received, including interference that may cause undesired operation.

This equipment has been tested and found to comply with the limits for a Class A Digital Device, pursuant to Part 15 of the FCC Rules. These limits are designed to this equipment generates, uses, and can radiate radio frequency energy and, if not installed and used in accordance with the instructions, may cause harmful interference to radio communications.

However, there is no guarantee that interference will not occur in a particular installation. If this equipment does cause harmful interference to radio or television reception, which can be determined by turning the radio or television off and on, the user is encouraged to try to correct interference by one or more of the following measures.

1. Reorient or relocate the receiving antenna.
2. Increase the separation between the equipment and receiver.
3. Connect the equipment into an outlet on another circuit.
4. Consult the dealer or an experienced radio/TV technician for help.



14. Warranty Policy and Limitation of Liability

IDTECK warrants this product against defects in material and workmanship for the period specified below from the date of purchase under normal customer use. This Warranty doesn't apply: 1) to any product which has been dismantled without authorization of IDTECK or/and has a damaged or detached QC label on its back side; 2) to any losses, defects, or damages caused by improper testing, operation, installation, maintenance, modification, alteration, or adjustment; 3) to any product with a damaged or faded serial number on it; or 4) to any losses, defects, or damages caused by lightning or other electrical discharge, natural disaster, misuse, accident or neglect.

This Limited Warranty is in lieu of all other warranties, obligations, or liabilities on the part of IDTECK, and IDTECK DISCLAIMS ANY AND ALL WARRANTY, WHETHER EXPRESS OR IMPLIED, OF MERCHANTABILITY OR FITNESS FOR A PARTICULAR PURPOSE. IDTECK does not, and cannot, know who is present, what property is located, where this product will be used; it would be extremely difficult to determine the actual damages that may result from a failure of the product to perform as anticipated; and the low price of this product is based upon the nature of the product provided and the limited liability that IDTECK assumes. IDTECK IS NOT RESPONSIBLE FOR ANY PERSONAL INJURY, PROPERTY DAMAGE OR LOSS, DIRECT, SPECIAL, INCIDENTAL OR CONSEQUENTIAL DAMAGES, OR OTHER LOSS, AND IDTECK'S MAXIMUM LIABILITY SHALL NOT IN ANY CASE EXCEED THE PURCHASE PRICE OF THE PRODUCT.

To obtain repair or replacement under the terms of this warranty, visit IDTECK's Website (<http://www.idteck.com>) and place an online RMA request. After an RMA code is issued, return the product along with the authorization RMA code.

>> Warranty Period

	Product Category	Warranty Period
1	RF CARD (Active type)	1 year
2	RF READER / FINGERPRINT READER	3 years
3	STANDALONE CONTROLLER	
4	CONTROL PANEL	
5	FINGERPRINT CONTROLLER	Lifetime
6	MOLDED RF READER (RF10, RF20, RF30, RF TINY, IP10, IP20, IP30, SR10E, SR10UE, SR10SE, SR10RWE, SR10BE)	
7	RF CARD (Passive type) (IDC80, IDC170, IDK50, IMC125, LXX50, IPC80, IPC170, IPK50, ISC80, ISC80S, ISK50, IMC135, IHC80, IP100, IP200)	

15. Template

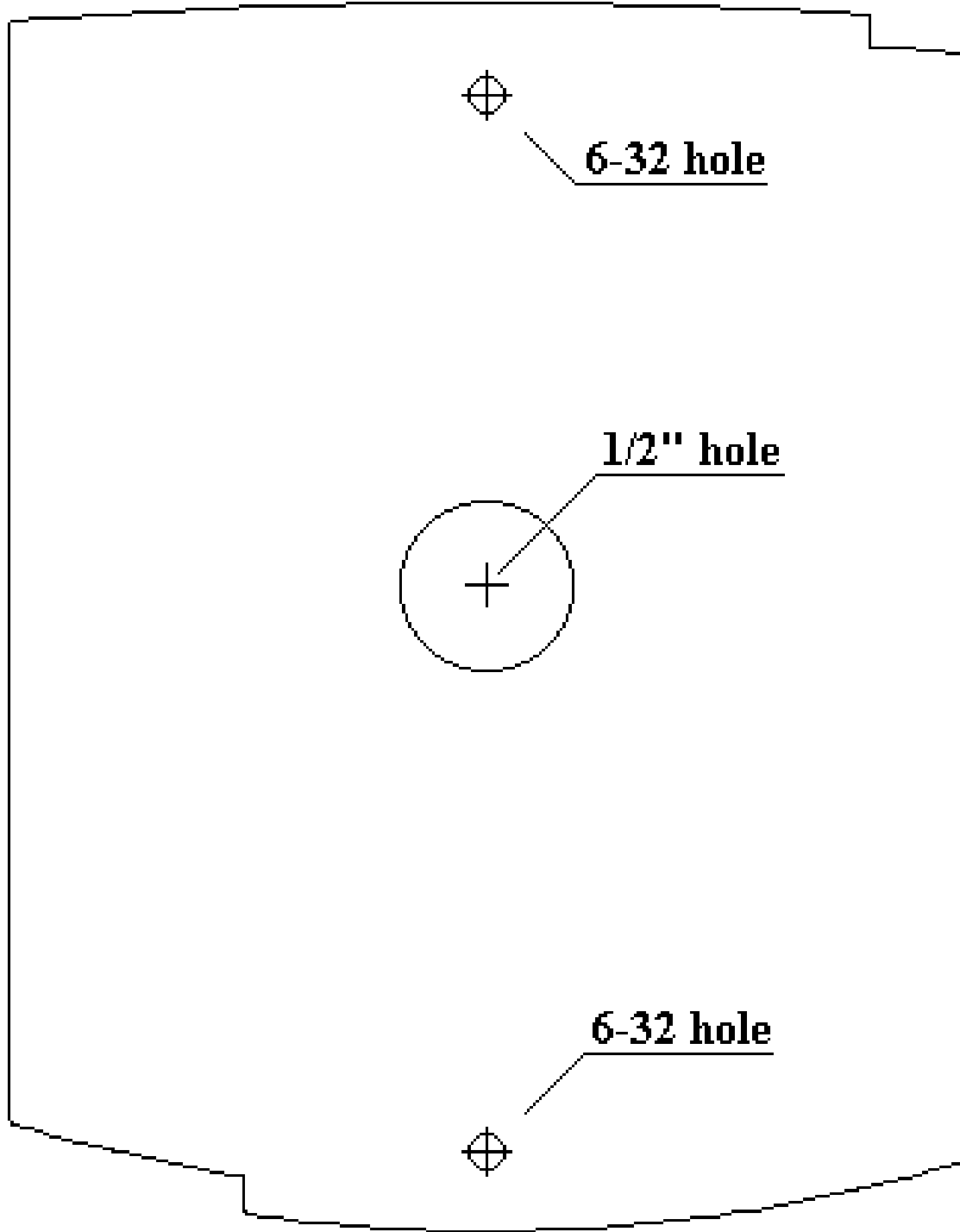

RMA REQUEST FORM

IDTECK accepts only on-line RMA requests on our Website (www.idteck.com). Please provide us with basic information in the below form so that we can understand your problems better. Send us back this form with your products after an RMA code is issued on our Website. This form is not compulsory.

Authorization RMA Code :	
1. Company Name	
2. Model Name	
3. Serial No.	
4. Original Invoice No.	
5. Distributor	
6. Purchasing Date	
7. RMA Request Date	

Please check your problems.

<input type="checkbox"/> Card Reading	<input type="checkbox"/> Power	<input type="checkbox"/> Keypad
<input type="checkbox"/> Communication	<input type="checkbox"/> Relay	<input type="checkbox"/> LCD
<input type="checkbox"/> LED & Buzzer	<input type="checkbox"/> Registration	
<input type="checkbox"/> Others :		

IDTECK RMA Center >>

3F, 10/10-1/10-2, Dodang-Dong, Weonmi-Gu, Bucheon-Si, Gyeonggi-Do 157-030, Korea

Telephone: 82.2.2659.0055 (HQ) / 82.32.671.5642 (RMA Center)

Fax: 82.2.2659.0086 (HQ) / 82.32.671.5641 (RMA Center)

Website: www.idteck.com

e-Training Center: www.idtecktraining.com



The specifications contained in this manual are subject to change without notice at any time.

5F, Ace Techno Tower B/D, 684-1, Deungchon-Dong,
Gangseo-Gu, Seoul, 157-030, Korea

Tel : +82-2-2659-0055

Fax : +82-2-2659-0086

E-mail : webmaster@idteck.com